

# User's Guide

Version 1.12



## Photometer/Radiometer

---

Model PMA2200 Ver 1.12  
Solar Light Company, Inc.

© 2001 Solar Light Company. All rights reserved.

100 East Glenside Avenue  
Glenside, PA 19038  
USA

Tel: (215) 517-8700  
Fax: (215) 517-8747  
info@solarlight.com  
www.solarlight.com

US Patent 5,790,432

ProComm is a registered trademark of Symantec Corporation.  
Windows is a registered trademark of Microsoft Corporation.

# Contents

## **USER'S GUIDE** **1**

---

### **CONTENTS** **3**

---

#### **INTRODUCTION** **5**

---

<b>PMA2200 DESIGN CONCEPT</b>	<b>5</b>
<b>MAJOR FEATURES</b>	<b>6</b>
<b>CURRENTLY SUPPORTED DETECTORS</b>	<b>6</b>

#### **QUICK START** **8**

---

<b>SELECTION OF THE DETECTOR</b>	<b>8</b>
<b>MEASURING WITH PMA2200</b>	<b>8</b>

#### **CONTROLS AND INDICATORS** **9**

---

<b>DISPLAY</b>	<b>9</b>
<b>KEYPAD</b>	<b>10</b>
<b>AUDIBLE SIGNALS</b>	<b>11</b>
<b>ERROR MESSAGES</b>	<b>11</b>

#### **SETUP** **12**

---

<b>METER SETUP</b>	<b>12</b>
<b>REAL TIME CLOCK AND CALENDAR: FUNCTION "T" AND "D"</b>	<b>12</b>
<b>RS232 DATA PRINTING: FUNCTION "O"</b>	<b>13</b>
<b>DETECTOR SETUP</b>	<b>13</b>

#### **DATA MANAGEMENT** **14**

---

<b>DATA LOGGING</b>	<b>14</b>
<b>DATA PROCESSING</b>	<b>14</b>

---

<b>INTERFACES</b>	<b>17</b>
<b>DETECTOR INTERFACE</b>	<b>17</b>
<b>SERIAL AND EXTENSION PORT</b>	<b>18</b>
<b>DIGITAL CONTROL LINES</b>	<b>20</b>
<b>TECHNICAL SPECIFICATIONS</b>	<b>22</b>
<b>MAINTENANCE AND TROUBLESHOOTING</b>	<b>23</b>
<b>METER CALIBRATION</b>	<b>23</b>
<b>TABLE OF FIGURES</b>	<b>24</b>
<b>INDEX</b>	<b>25</b>

---

## Introduction

The Personal Measurement Assistant model PMA2200 is a sophisticated, multipurpose measuring instrument that combines the user-friendliness of simple meters.

### ***PMA2200 design concept***

The combination of simplicity of use and enhanced features was possible thanks to the implementation of microprocessor technology and an innovative architecture.

The meter itself is programmed to perform the tasks common to most detectors. The information specific for a particular detector is stored in a nonvolatile memory built into the detector itself. It

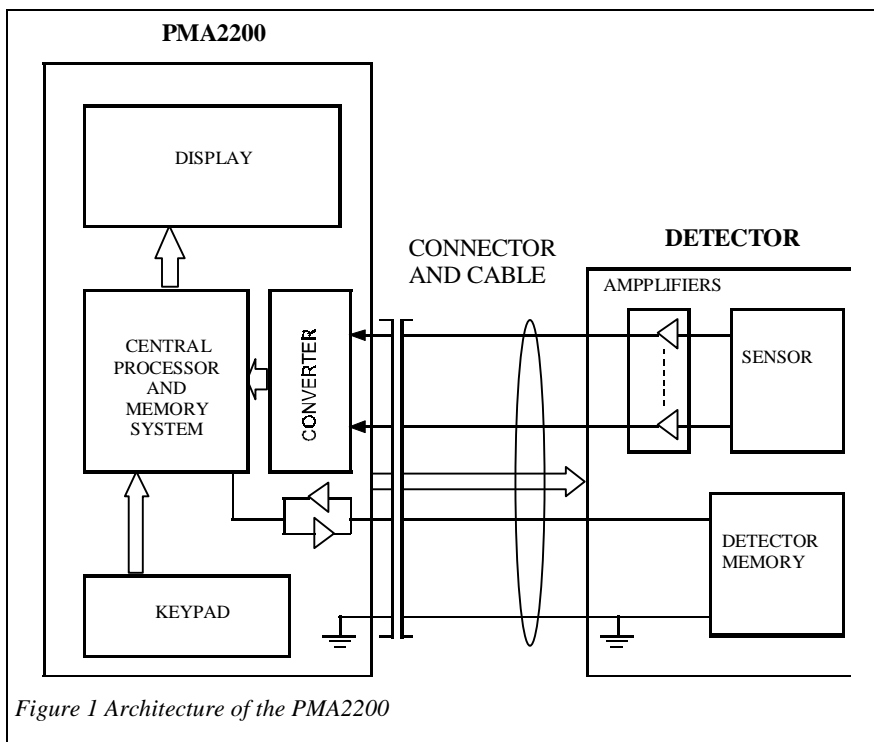

includes identification information, signal-processing algorithms, a description of the data presentation, and the current setup of the detector.

Upon connection of a detector the PMA2200 identifies it, downloads the contents of the detector's memory into the operating memory, updates its setup and executes the downloaded code, if appropriate.

This approach allows for an unlimited number of detectors to be supported by the PMA2200. It configures itself to the specific features of each detector and the custom setup of the measurement process.

## ***Major features***

Measuring with the PMA2200 is as simple as with the usual single detector and meter. Plug a detector into the input socket, turn ON power and read the display. The many additional capabilities of the PMA2200 Version 1.12 include:

- User selectable system of units
- Integration of the accumulated dose (where applicable)
- Tracking of the extremes of the signal (min., max., avg.)
- RS232 serial interface
- Digital inputs and outputs to control external devices

## ***Currently supported detectors***

For a complete list of detectors, please refer to the detector selection guide at [www.solar.com/detector.htm](http://www.solar.com/detector.htm).

The PMA2200 family currently includes a variety of detectors for such parameters as:

- biologically effective UV radiation (UV-B)
- UV-A radiation
- UV safety detector
- Germicidal UV
- Photopic
- Scotopic
- PAR (photosynthetic)
- Continuous lasers
- blue light safety detector
- illumination (photopic and scotopic)
- temperature
- humidity

---

The PMA2200 can be used in any application where an accurate measurement is required, especially if multiple quantities are measured or the enhanced functionality of the meter is desired. Potential applications include:

- laboratory measurements
- environmental monitoring
- industrial safety
- UV-curing, printing and photolithography
- photodermatology and photobiology
- cosmetic industry, SPF testing
- agriculture

Any sensor producing up to 4 analog signals can be quickly and inexpensively accommodated by the PMA2200, making it attractive to sensor manufacturers who would like to offer a state of the art meter with their product.

## Quick start

While sophisticated and powerful, the PMA2200 is a user-friendly instrument allowing for simple “plug-and-play” operation.

### *Selection of the detector*

A critical part of every measurement process is the sensor selection. The criteria that need to be addressed when making that decision are:

- the anticipated signal characteristics including spectral range
- environmental factors such as temperature range and humidity

The PMA2200 family includes detectors for indoor, permanent outdoor, and underwater operation, satisfying virtually any operating environment.

### *Measuring with PMA2200*

To perform measurements with a PMA2200 the following steps should be followed:

1. Power ON the PMA2200 by pressing the **ON/OFF** button. If the meter does not respond attach the external power supply. The unit will be powered ON whenever connected to the external power supply. The PMA2200 will turn itself OFF after 3 minutes of inactivity if no detector is attached.
2. Plug the selected detector into the detector input located on the side of the meter. The meter will indicate the connection by a beep and the display will show the measurement result. Squeeze the locking arms of the detector plug while connecting or disconnecting it.
3. In order to turn the PMA2200 OFF press the **On/Off** key. If the unit is connected to external power, it will remain powered up and pressing the **On/Off** will have no effect.

Refer to "**Controls and indicators**" on page 9 for detailed description of the PMA2200 "data mode" display.

## Controls and indicators

### Display

When the meter is turned **ON**, it displays a start-up screen (Figure 2) while performing the hardware test. The model number and software version number of the meter are briefly displayed.

Then, the display goes into the "data mode". If a detector is attached, the measurement results are shown (Figure 5 ). Otherwise the screen indicates that there is no detector connected (Figure 4).

The **HOLD** function is activated by pressing the **HOLD** key. When the data is flashing, the contents of the

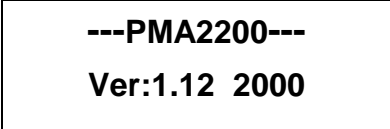

---PMA2200---  
Ver:1.12 2000

Figure 2 Start-up screen of the PMA2200 meter.



1.002 W/cm<sup>2</sup>

Figure 5 "data mode" with detector connected no integration

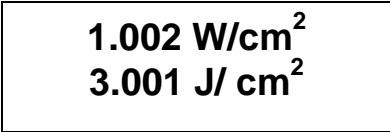

1.002 W/cm<sup>2</sup>  
3.001 J/ cm<sup>2</sup>

Figure 3 "data mode" with detector connected with integration

display are frozen; however, the measurements, dose integration or min/max/avg. (if enabled) will continue in the background. Pressing the **HOLD** key again reactivates the continuous data display.

The Low and High tracking can be initiated by pressing the **Min/Max** key. The same key clears the setting. The tracking of extremes starts from the moment the feature is activated. To re-start the tracking, turn the feature OFF then back ON by pressing the **Min/Max** key twice.

Averaging is activated by pressing the **Avg** key. The averaging starts from the moment the feature is activated. To re-start the averaging, turn the feature OFF then back ON by pressing the **Avg** key twice.



No Detector

Figure 4 Display in the "data mode" with no detector connected.

The instantaneous reading is displayed with the currently selected units to the right of the measurement result. If alternative units are available, pressing the **Units** key will convert the result to alternative units. There can be more than two unit systems. They can be selected by pressing the **Units** repeatedly. After the last unit selection is reached, pressing the **Units** key will bring the display back to the initial unit selection.

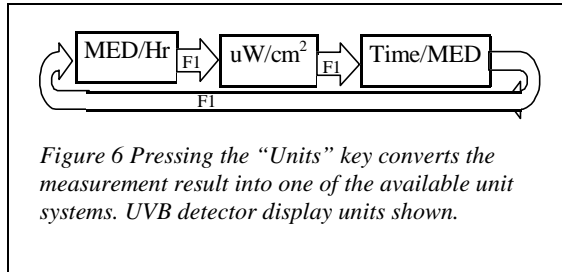

*Figure 6 Pressing the “Units” key converts the measurement result into one of the available unit systems. UVB detector display units shown.*

If the measured quantity can be integrated over time, then an integration can be initiated by pressing the **Int** key. The integrated value of the integration is displayed in the space below the instantaneous measurement value (Figure 3). Pressing the **Int** key again stops the integration.

The dose display freezes but the information is displayed on the LCD until the **Int** key is pressed again. When restarted, the integrated value will be reset to zero. Integration can not be used when using the Min/Max or Avg features.

The assignment of the function key, **F1**, can change dynamically depending on the mode of operation. The function of the key is described by pressing **F1**. If the function key is defined for the detector being displayed, the definitions of the key will appear on the second line of the display. Pressing **F1** a second time will perform the defined operation.

## Keypad

The keys of the PMA2200 (Figure 7) have a tactile feel and an audible signal is generated when the key is pressed.

The **On/Off** key toggles the power to the meter. It is only active in the display mode.

The **Int** button enables the dose integration. The integrated dose is in the space shown below the instantaneous measurement result (Figure 3). Pressing the **Int** button a second time stops the integration, and pressing the third time clears the integration from the screen.

Pressing the **HOLD** key, freezes the information on the LCD, without affecting the measurement and data collection process. The displayed data will begin to flash. While in the “hold mode” pressing **HOLD** a second time reactivates display updating.

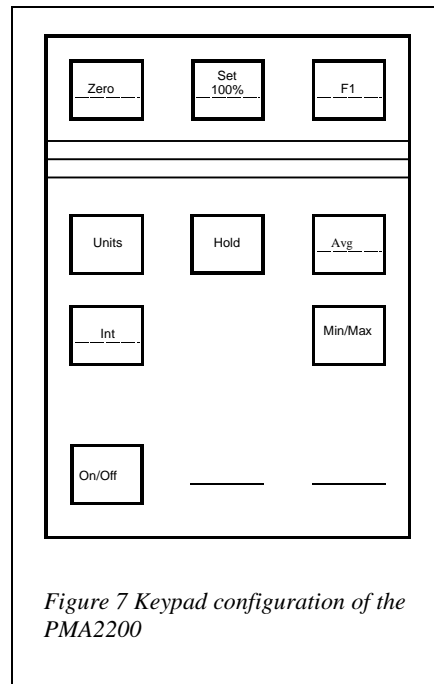

*Figure 7 Keypad configuration of the PMA2200*

The **Min/Max** key initiates the Low and High tracking. The same key clears the setting. The tracking of extremes begins from the moment the feature is activated. To re-start the tracking turn the feature OFF then back ON by pressing the **Min/Max** key twice. High and low values will be reset to zero on restart of the **Min/Max** function.

The **Avg** key initiates averaging. The same key clears the setting. The averaging begins from the moment the feature is activated. To re-start the averaging turn the feature OFF then back ON by pressing the **Avg** key twice. The average value will be reset on restart of the **Avg** function.

The **Zero** key will zero any offset for the detector. This function is also useful for relative measurements between two sources.

Pressing the **Set 100%** key will take the current instantaneous reading and set it to 100% (100% will be seen on the display). Any variations in the reading will be indicated in percent transmission. This feature is useful for measuring transmission of filters or materials.

## ***Audible signals***

Certain conditions cause a generation of an audible signal to attract the user's attention. The conditions generating an audible signal are listed in Table 1.

*Table 1 Conditions causing a generation of an audible signal.*

power on	1 long beep
activation of any key	1 short beep
acceptance of an newly connected detector	1 short beep
detector disconnected	3 short beeps
Detector out of range (max value exceeded)	Short ticks
Error	1 long beep

## ***Error messages***

When an erroneous condition is detected by the PMA2200 an error message is displayed to indicate the nature of the problem.

*Table 2 Error codes and messages*

<b>Code</b>	<b>Message on LCD</b>	<b>Description of the problem</b>
02	Upgrade software	The detector requires a higher version of the software controlling the PMA2200. The message is displayed immediately after the new detector is connected. Contact the manufacturer for upgrade.
03	Out of cal	The detector is due for calibration. The detector should be returned to manufacturer for re-calibration.

# Setup

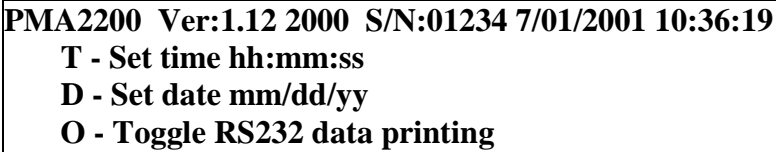

```
PMA2200 Ver:1.12 2000 S/N:01234 7/01/2001 10:36:19
T - Set time hh:mm:ss
D - Set date mm/dd/yy
O - Toggle RS232 data printing
```

*Figure 8 setup screen for the PMA2200 meter.*

## ***Meter setup***

### **Real time clock and calendar: Function “T” and “D”**

The real time clock and calendar provides the information for time-stamping of the recorded data.

To set the real time clock/calendar, follow these steps:

1. Connect the PMA2200 to an available serial port on a PC using an AT modem cable.
2. Start a communications program such as ProComm or Windows Terminal or HyperTerminal.
3. Configure the Comport as follows:
  - Baud rate 19200
  - Handshake None
  - Data bits 8
  - Parity None
  - Stop bits 1
4. Press **Enter** to get a menu from the PMA2200. (Figure 8)
5. Press “**D**” to set the date or “**T**” to set the time.

## **RS232 data printing: Function “O”**

The RS232 data printing function allows the user to display and/or capture the data from the detector to a file via RS232. Follow steps 1-4 in the Real time clock and calendar section for the computer connection and display. Press “O” to toggle the data printing on and off. The data is updated and displayed about three times per second.

Open a file to capture the data if it is to be stored. Before the PMA2200 is connected a description can be annotated. For example, light source type, distance, filters, experiment name, etc. Connect the PMA2200 and press **Enter**. Press “O” to toggle the RS232 on when the detector setup is complete and you are ready to start storing data.

The data format displayed is shown in Table 3 and the description is shown in Table 5.

## ***Detector Setup***

The detectors are equipped with a non-volatile memory to store configuration information specific to a particular detector. When the detector is connected, these configuration parameters are read from the detector and used to set up the PMA.

# Data management

## Data logging

The PMA2200 does not have internal datalogging capability. However, the PMA2200 can transmit data by RS232 serial interface. The PMA2200 can be connected to a PC running a communications software package. The PC can then function as a datalogger saving data records to file. Refer to “**Setup**” on page 12 for instructions to use a PC to store data from the PMA2200.

The data are downloaded in a text format following the template shown in Table 3.

Table 3 Format of the data downloaded from PMA2200

Detector model #	detector serial #	record date	record time	recorded value	Units	Scale	Flags	Calibration due-date
------------------	-------------------	-------------	-------------	----------------	-------	-------	-------	----------------------

Table 4 Example of data records from the PMA2200

RS232 printing Enabled.
30,"02258","09/23/1998","09:47:00",2.3895E+03,"Lux",1.00,00,"09/1999"
30,"02258","09/23/1998","09:47:01",2.4312E+03,"Lux",1.00,00,"09/1999"
RS232 printing Disabled.

Commas separate the fields. The non-numerical values, such as serial number, date, time and units are enclosed in quotes to comply with a commonly used **Comma and Quote Separated Format**.

Table 5 contains detailed description of the individual fields of the data record. Refer to the "**Data processing**" chapter below for additional information about importing and processing the data.

## Data processing

The data downloaded from the PMA2200 can be imported into any commercial spreadsheet or data processing package supporting the import of data in **Comma and Quote Separated Format**.

As an example, the steps necessary to import a data file into Microsoft Excel 2000 are listed:

1. Download the data from the PMA2200 and save in a file called PMA.TXT.
2. Open Microsoft Excel.
3. Place the cursor on an empty page in a cell where you want the data block to begin

4. From the menu select **Data**, then **Get External Data**, and then **Import Text File...**
5. In the Import Text File dialog locate and select your data file. In this case PMA.TXT.
6. In the Import Text Wizard select **Delimited** for the Original File Type and click **Next >**.
7. Select **Comma** as the Delimiter and “**”** as the Text Qualifier and click **Finish**.
8. Select the location where your data will be imported and click **Ok**.

The data is downloaded into the spreadsheet and can be manipulated with the various tools built into this software. Some programs have built-in import wizards that analyze the format of the file and facilitate the data import. A macro can be created in most spreadsheet programs to automate the import of downloaded data.

Table 5 Description of the data record format

<b>Field</b>	<b>Contents</b>	<b>Type</b>
<b>Detector model #</b>	The last two digits of the detector type. For example the detector PMA2131 has the type code 31.	Numerical
<b>Detector serial #</b>	The string containing the serial number of the detector	Enclosed in ""
<b>Record Date</b>	The date stamp of the measurement. The date is formatted as follows: mm/dd/yyyy where: mm = month, dd = day, yyyy = year	Enclosed in ""
<b>record time</b>	The time stamp of the measurement. The time is formatted as follows: hh:mm:ss where: hh = hours, mm = minutes, ss = seconds	Enclosed in ""
<b>Recorded value</b>	The measurement result	Numerical
<b>Units</b>	Units used for measurement result	Enclosed in ""
<b>Scale</b>	Scale of the detector (1.00 nominal) - future use only	
<b>Flags</b>	Flags set when data recorded – future use only	
<b>Calibration due date</b>	The date the detector is due for calibration. The date is formatted as follows: mm/yyyy where: mm = month, yyyy = year	Enclosed in ""

# Interfaces

## ***Detector interface***

The PMA2200 detector interface provides connections for the detector's analog signals, the power for the detector and the digital interface for the detector's memory.

The single PMA2200 detector interface (port) provides 4 independent analog inputs, designated *Input0* through *Input3*. These direct inputs accept signals in a range of -4V to +4V. Table 6 provides detailed functional description of the individual pins.

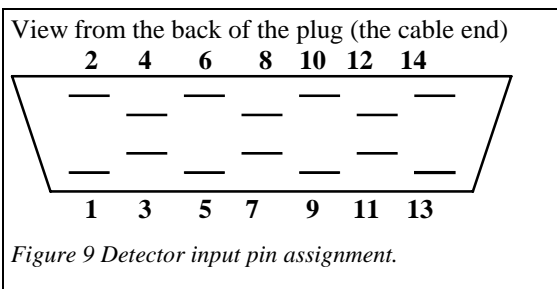

Table 6 PMA2200 detector interface configuration

Pin Number	Signal description	Specifications
1	Analog input 1 or 5	$\pm 4V$ full scale, 2.7K series 0.1 $\mu$ f to ground
2	Analog input 2 or 6	$\pm 4V$ full scale, 2.7K series 0.1 $\mu$ f to ground
3	Analog input 3 or 7	$\pm 4V$ full scale, 2.7K series 0.1 $\mu$ f to ground
4	Analog input 4 or 8	$\pm 4V$ full scale, 2.7K series 0.1 $\mu$ f to ground
5	Analog ground	Internally connected to power/digital ground - do not connect to power GND inside the detector
6	Detector presence 1	Used to determine if detector connected
7	Detector presence 2	Used to determine if detector connected
8	Detector decode 1	Used to determine detector port used
9	Detector clock	Clock for non-volatile memory - ESD protected
10	Detector decode 2	Used to determine detector port used
11	-5V power	50mA max., short circuit protected
12	+5V power	50mA max., short circuit protected
13	Power and digital ground (connected to shield inside the PMA2200 meter)	do not connect to analog GND inside the detector
14	Data I/O	Data line for non-volatile memory - ESD protected
SHIELD	Power and digital ground (connected to pin 13 inside the PMA2200 meter) not connected to connector shell.	

## Serial and extension port

The PMA2200 is equipped with a RS232C serial port allowing communication with a computer or a serial printer. The serial communication lines, along with other analog and digital signals, available on the 25 pin female D-connector located on the bottom of the meter.

To connect the PMA2200 to the IBM-PC compatible computer, a standard AT modem cable can be used in place of the one that is provided with the meter. The baud rate of the serial port is preset at 19200bps.

Due to the power-saving features built into the PMA2200, the serial port's transmitter operates properly only if there is no incoming transmission, i.e. the receiving line must be in a negative (marking) state. The PMA2200's receiver works properly all the time.

*Table 7 Serial communication and extension port connector*

<b>Pin Number</b>	<b>Signal description</b>	<b>Specifications</b>
1	Optical Output 0	Refer to fig 8
2	RxD - Data input	Switching threshold approx. 1.5V, with 0.5V hysteresis; accepts standard RS232C levels
3	TxD - Data output	high state : +5V low state : equal to the RxD's low level
4	DCD - Data Carrier Detect Input	RS232C levels
5	Optical input 0	Refer to fig 9
6	Optical Input 1	Refer to fig 9 (not used for PMA2200)
7	GROUND	Digital ground
8	Optical Input ground	Refer to fig 9
9	+5V Power	50mA max., short circuit protected
10	-5V Power	50mA max., short circuit protected
11	Analog input 3	±4V full scale, 2.7K series 0.1uf to ground
12	Analog input 2	±4V full scale, 2.7K series 0.1uf to ground
13	Analog Input 0	±4V full scale, 2.7K series 0.1uf to ground
14	Optical Output 1	Refer to fig 8 (not used for PMA2200)
15	Analog Input 6/Analog Output, Positive	±4V full scale, 2.7K series 0.1uf to ground
16	Detector clock	Clock for non-volatile memory - ESD protected
17	Data I/O	Data line for non-volatile memory - ESD protected
18	Detector presence 3	Used to determine if detector connected
19	Analog Input 7/Analog Output, Ground	±4V full scale, 2.7K series 0.1uf to ground
20	Processor Selector	Not Used for PMA2200
21	Analog Input 5	±4V full scale, 2.7K series 0.1uf to ground
22	Optical Output ground	Refer to fig 8
23	Analog Input 4	±4V full scale, 2.7K series 0.1uf to ground
24	Analog Ground	Analog ground
25	Analog Input 1	±4V full scale, 2.7K series 0.1uf to ground

The PMA2200 can be controlled from a remote computer via an external modem. The modem connected to the PMA2200 should be set to auto-answer in order to pick-up the incoming calls automatically. The modem's result codes should also be disabled. For modems supporting the Hayes AT commands the following programming sequence is adequate:

```
AT&D0Q1E0S0=2&C1&W0&Y0
```

This sequence should be transmitted to the modem from a PC before this modem is connected to the PMA2200. Only the remote modem picking up the calls to the PMA2200 has to be set up in this way. The PMA2200 is not able to dial the telephone number so the calls cannot originate from the PMA2200. Table 8 shows the cable connections between the PMA2200 and the modem.

Table 8 PMA2200 to modem connection

PMA DB25 connector		Modem DB25 connector	
Pin number	Signal	Pin number	Signal
2	RxD	3	TxD
3	TxD	2	RxD
7	GND	7	GND

### Digital control lines

The digital control lines of the PMA2200 can be used to control an external device, such as a relay or valve, acting as a closed loop feedback system or as a dose controller. An example application is the monitoring and control of greenhouse temperature and the amount of light.

The PMA2200's digital control lines provide 1 optically coupled input and 1 optically coupled output designed to connect with control equipment. The pins of the digital control lines are available on the 25-pin connector, which also accommodates the pins of the serial port.

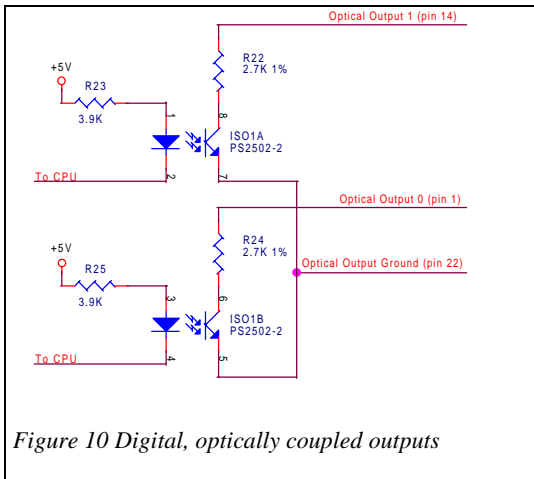

Figure 10 Digital, optically coupled outputs

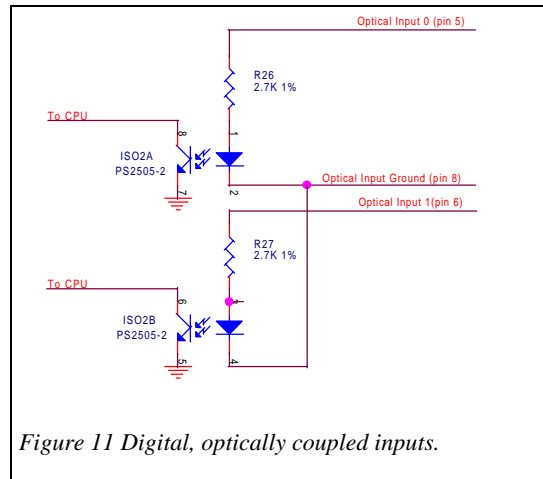

Figure 11 Digital, optically coupled inputs.

The optically coupled I/O's functions depend on the detector connected to the PMA2200. Typically these outputs are not used, however, some custom or specialized detectors may use these ports for external control.

## Technical specifications

Detector inputs	1 detector input with up to 4 analog signals.
Input ranges	$\pm 4\text{V}$ , single range (autoranging not necessary)
Resolution	3uV ( $\pm 4\text{V}$ range)
Dynamic range	$2.6 \cdot 10^6$ (6.5 digits)
Accuracy	Within 0.2% FS
Non-linearity	0.003% Integral non-linearity
Temperature coefficient	max. 50 ppm/ $^{\circ}\text{C}$
Sampling rate	3 per second
Screen Refresh Rate	10 per sec
Operating temperature	0 to 50 $^{\circ}\text{C}$ (non condensing)
Power consumption	Approx. 110 mW
Batteries	4xAA Alkaline batteries
Battery life	>40 hours continuous use
External power	9-12V AC or DC adapter, 100mA min
Weight	18 oz (510 grams)
Size	4"W x 7.6"H x 1.75"D (10 x 19.3 x 4.35 cm)
LCD Size	2.5" x 0.5" (6.4 x 1.3 cm)
User interface	9-button keypad

## Maintenance and troubleshooting

### *Meter calibration*

Both the PMA2200 meter and the detectors have to be calibrated to assure accurate measurements.

The analog inputs of the PMA2200 are initially calibrated with an accuracy of 0.2% and the calibration factors are stored in its internal memory. The internal real time clock is accurate to within 1 minute/month. Since there are no mechanically adjustable components in the meter, its calibration is extremely stable. Nonetheless, the calibration should be periodically checked. The recommended calibration interval is one year. The calibration is done in a computerized tester and must be performed by the manufacturer or by an authorized laboratory. Please contact Solar Light Company for further information.

The calibration of the detectors is independent from the meter's calibration. The detector calibration accuracy depends on the type of detector. It should be performed at least annually. The calibration can be performed by the manufacturer or by an authorized laboratory.

## Table of figures

<i>Figure 1 Architecture of the PMA2200</i>	5
<i>Figure 2 Start-up screen of the PMA2200 meter.</i>	9
<i>Figure 3 "data mode" with detector connected with integration</i>	9
<i>Figure 4 Display in the "data mode" with no detector connected.</i>	9
<i>Figure 5 "data mode" with detector connected no integration</i>	9
<i>Figure 6 Pressing the "Units" key converts the measurement result into one of the available unit systems. UVB detector display units shown.</i>	10
<i>Figure 7 Keypad configuration of the PMA2200</i>	10
<i>Figure 8 setup screen for the PMA2200 meter.</i>	12
<i>Figure 9 Detector input pin assignment.</i>	17
<i>Figure 10 Digital, optically coupled outputs</i>	20
<i>Figure 11 Digital, optically coupled inputs.</i>	20

# INDEX

- Applications, 7
- Audible signals**, 11
- Averaging, 9
- Avg, 9, 10, 11
- Calendar**, 12
- Calibration, 23
- Clock**, 12
- Controls**, 8, 9
- Data**
  - format, 14
  - importing, 15
  - logging, 14
  - management**, 14
  - processing, 14
- Data mode, 9
- Detector interface, 17
- detectors, 8
  - selection, 8
- Detectors, 6
  - connecting, 8
  - setup, 5, 13
- Diagnostic, 9
- Digital control lines, 20
- Dose, 6
- Function keys, 10
- HOLD, 9, 10
- Importing data**, 15
- Indicators, 9
- Int, 10
- Integration, 6, 10
- Interfaces, 17
- Keypad, 10
  - Avg, 11
  - F1, 10
  - Hold, 9, 10
  - Int, 10
  - Min/Max, 11
  - On/Off, 10
  - Set 100.0%, 11
  - Units, 10
  - Zero, 11
- Maintenance, 23
- Min/Max
  - tracking, 9
- Model number, 9
- Modem connection, 20
- On/Off, 8
- PMA2200
  - Applications, 7
  - design concept, 5
  - detectors, 6
  - features, 6
  - measuring with, 8
  - setup, 12
- Real time clock**, 12
- Serial port, 18
  - cable, 18
- Set 100%, 11
- Technical specifications, 22
- Time**, 12
- Tracking min. and max., 6, 11
- Tracking min/max, 9
- Troubleshooting, 23
- Units, 6, 10
- Zero, 11