

USER'S GUIDE

MICROTOPS II

Sunphotometer Version 5.5

Solar Light Company, Inc.

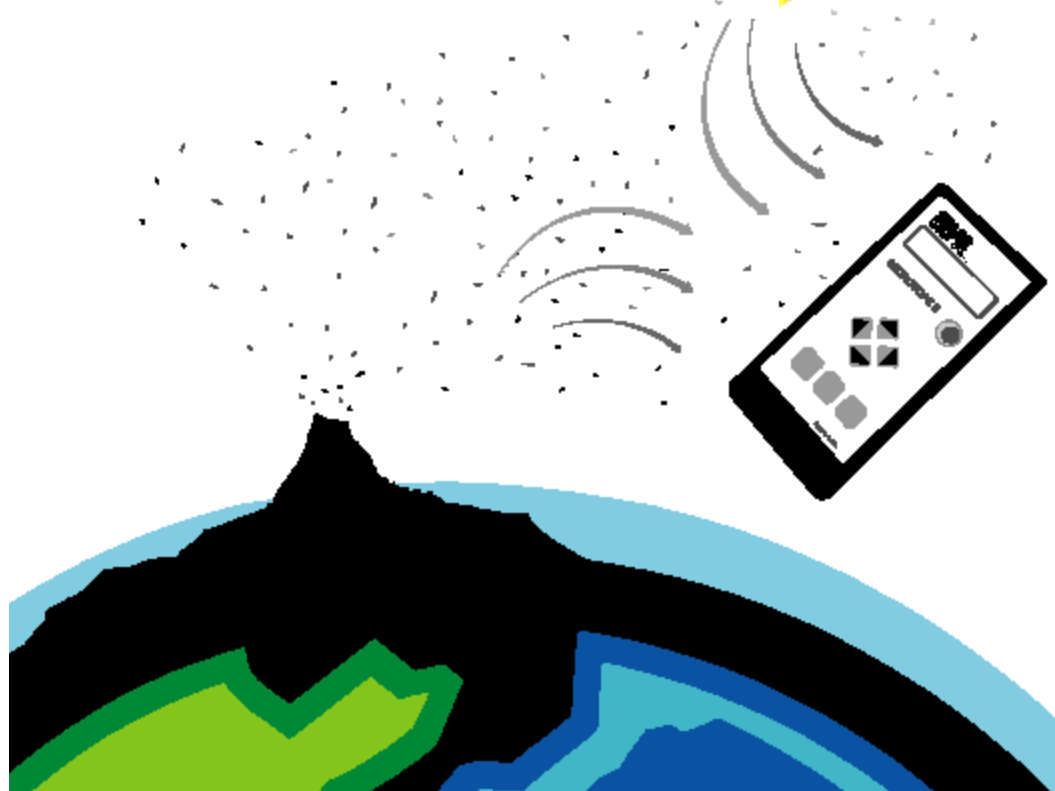

© 2003 Solar Light Company. All rights reserved.
100 East Glenside Avenue
Glenside, PA 19038
USA

Tel: (215) 517-8700
Fax: (215) 517-8747
info@solarlight.com
www.solarlight.com

Document No. MTP06 July 2003
Printed in the United States of America

Contents

1	INTRODUCTION.....	5
1.1	PRINCIPLE OF OPERATION.....	5
1.2	MAJOR FEATURES.....	5
2	QUICK START.....	7
2.1	POWER UP.....	7
2.2	MENU STRUCTURE.....	7
2.3	BEFORE MAKING FIRST MEASUREMENT.....	8
2.4	FIRST MEASUREMENT.....	8
3	SETUP.....	10
3.1	REAL TIME CLOCK.....	10
3.1.1	<i>Setting the time and date.....</i>	<i>10</i>
3.1.2	<i>Clock trimmer.....</i>	<i>11</i>
3.2	MEASUREMENT PARAMETERS AND CALIBRATION CONSTANTS.....	12
3.2.1	<i>Calibration constants.....</i>	<i>12</i>
3.2.2	<i>Data processing.....</i>	<i>16</i>
3.3	LOCATION SETUP.....	18
3.3.1	<i>Saved locations.....</i>	<i>19</i>
3.3.2	<i>Coordinates.....</i>	<i>19</i>
3.3.3	<i>Altitude.....</i>	<i>20</i>
3.3.4	<i>Pressure.....</i>	<i>20</i>
3.4	DATA LOGGING.....	21
3.4.1	<i>Viewing the stored data.....</i>	<i>21</i>
3.4.2	<i>Clearing the memory buffer.....</i>	<i>22</i>
3.4.3	<i>Deleting last measurement.....</i>	<i>23</i>
3.5	BAUD RATE.....	24
4	COMPUTER COMMUNICATION.....	25
4.1	PHYSICAL CONNECTION.....	25
4.2	REMOTE CONTROL.....	26
4.2.1	<i>Listing and setting current location.....</i>	<i>26</i>
4.2.2	<i>Clearing data buffer.....</i>	<i>27</i>
4.2.3	<i>Listing and setting saved locations.....</i>	<i>27</i>
4.2.4	<i>Downloading the data buffer.....</i>	<i>28</i>
4.2.5	<i>Initiating a scan.....</i>	<i>28</i>
4.2.6	<i>Setting date and time.....</i>	<i>28</i>
4.2.7	<i>Printing calibration constants.....</i>	<i>30</i>

5	MICROTOPS ORGANIZER SOFTWARE	31
5.1	INTRODUCTION	31
5.1.1	<i>Software installation</i>	31
5.1.2	<i>Communication setup</i>	31
5.2	MICROTOPS OPERATION	32
5.2.1	<i>Downloading data</i>	32
5.2.2	<i>Clearing the data buffer</i>	32
5.2.3	<i>Modifying stored MICROTOPS II locations</i>	33
5.3	DATABASE OPERATIONS	34
5.3.1	<i>Changing location names in the computer database</i>	34
5.3.2	<i>Importing text files</i>	34
5.3.3	<i>Importing files in data exchange format</i>	35
5.3.4	<i>Exporting in data exchange format</i>	35
5.3.5	<i>Data description</i>	35
6	GPS COMMUNICATION	36
6.1	SETTING UP GPS.....	36
7	MAINTENANCE	38
7.1	CLEANING AND STORAGE	38
7.2	BATTERY MAINTENANCE	38
7.3	CALIBRATION	38
8	SPECIFICATIONS.....	40
9	THEORY OF OPERATION.....	41
9.1	INTRODUCTION	41
9.2	BASICS OF THE INSTRUMENT.....	42
9.3	INSTRUMENT DESIGN	42
9.3.1	<i>Optical block</i>	42
9.3.2	<i>Signal conditioning and processing</i>	44
9.3.3	<i>Sun targeting</i>	45
9.4	CALIBRATION AND MEASUREMENT OF OZONE	46
9.5	DERIVATION OF WATER VAPOR	49
9.6	CONCLUSIONS	51
9.7	REFERENCES:	51
10	TABLE OF FIGURES.....	53
11	INDEX.....	54

1 Introduction

The MICROTOPS II is a hand-held multi-band sunphotometer capable of measuring the aerosol optical thickness (AOT) and direct solar irradiance in each band. Optionally the MICROTOPS II is capable of deriving the water vapor column (also called precipitable water).

1.1 Principle of operation

The instrument is equipped with five (5) accurately aligned optical collimators, with a full field view of 2.5°. Internal baffles are also integrated into the device to eliminate internal reflections. Each channel is fitted with a narrow-band interference filter and a photodiode suitable for the particular wavelength range. The collimators are encapsulated in a cast aluminum optical block for stability.

A sun target and pointing assembly is permanently attached to the optical block and laser-aligned to ensure accurate alignment with the optical channels. When the image of the sun is centered in the bull's-eye of the sun target, all optical channels are oriented directly at the solar disk. A small amount of circumsolar radiation is also captured, but it makes little contribution to the signal.

Radiation captured by the collimator and bandpass filters radiate onto the photodiodes, producing an electrical current that is proportional to the radiant power intercepted by the photodiodes. These signals are first amplified and then converted to a digital signal by a high resolution A/D converter. The signals from the photodiodes are processed in series. However, with 20 conversions per second, the results can be treated as if the photodiodes were read simultaneously.

AOT and water vapor column are determined assuming the validity of the Bouguer-Lambert-Beer law. The optical depth due to Rayleigh scattering is subtracted from the total optical depth to obtain AOT. Optical depth from other processes such as O₃ and NO₂ absorption are ignored in MICROTOPS II.

The water vapor column is determined based on measurements at 936nm (water absorption peak) and either 870nm or 1020nm (no absorption by water vapor).

A more detailed description of the functioning of the instrument along with the calibration procedures is enclosed in the accompanying paper on page 41.

1.2 Major features

- **High accuracy.** High-grade filters are embedded in a solid cast aluminum housing that assures accurate, stable optical alignment. Low noise electronics and a 20-bit A/D converter ensure high linearity, resolution and dynamic range.
- **Ease of use.** No computer knowledge is necessary to take measurements. Once the geographical coordinates of the measurement site are entered, just aim the meter at the sun, align the image of the sun with the bull's-eye and push the button. In seconds the result will be dis-

played on the LCD.

- **Portability.** A small hand-held device is all you need to take measurements. No additional computer is necessary.
- **Computer interface.** A serial interface allows for the transfer of data and remote control of the instrument from any computer. Simple text protocol makes the process easy and dependable. Specialized data management software is available as an option.
- **GPS interface.** Microtops II understands the NMEA 0183 communication protocol and can be linked directly to a hand-held GPS receiver via serial cable. The GPS receiver is optional.
- **Instantaneous results.** The AOT, irradiance, and total water vapor calculation algorithms are programmed in the MICROTOPS II and the results of all stored scans can be conveniently viewed on the LCD. The raw data is also stored to allow retrospective adjustments of calibration constants.
- **Non-volatile memory.** The raw data collected by MICROTOPS II, as well as calculated results are stored in non-volatile memory. Each data point is annotated with date, time, site coordinates, solar angle, altitude, pressure and temperature.
- **Low cost.** By implementing the latest technology, instrument cost has been brought below that of comparable sunphotometers, without sacrificing accuracy or features.

2 Quick start

2.1 Power up

To turn ON MICROTOPS II press the **ON/OFF** switch for about 1/2 second. It will not react to a brief touch. For about 2 seconds the display shows "Hardware test" message and the version number of the firmware loaded into the instrument. For the next 2 seconds the "Initialization - keep covered" message is displayed. Keep the top window cover closed until the display shows **RDY** (ready mode). To turn the instrument OFF press the **ON/OFF** button again. It will turn off only when in the ready mode. Otherwise the **ON/OFF** button is not active. To return to ready mode from any other mode press the **Scan/Escape** button until the **RDY** message appears on the LCD. All buttons are inactive during the measurement scan. The meter will automatically shut off after 10 minutes of inactivity.

2.2 Menu structure

All settings for MICROTOPS II are accessible through a tree-organized menu. At the top of the menu structure is the **ready mode**, where the instrument is prepared to take measurements and displays the following information:

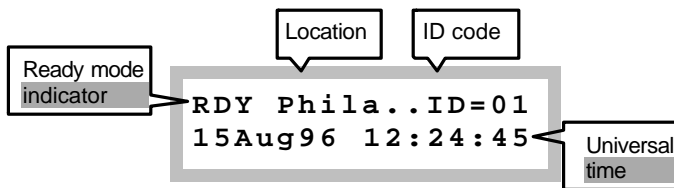

If the name of the selected location is 6 characters long or less it will be displayed in its entirety. Otherwise, only the first 5 characters are displayed followed by two dots indicating continuation. The named locations can be set from a PC via the serial port. See "**Remote control**" on page 26 for more details. If a manually entered (unnamed) location is used then the location name displays "Manual".

The ID code is a user-adjustable number that is stored with each scan. This number can be incremented/decremented with the **▲** or **▼** keys when in **ready mode**. Its purpose is to store auxiliary user-defined information such as sky conditions during measurement or operator's code etc.

The menu can be accessed by pressing the **Menu/Enter** key while in the ready mode. The simplified structure of the entire menu is shown in Figure 1. Within the same level move with **▲** or **▼** keys. Enter a lower level by pressing **▶** or **Enter**, and quit to an upper menu by pressing **Escape** or **◀** (**Es-**

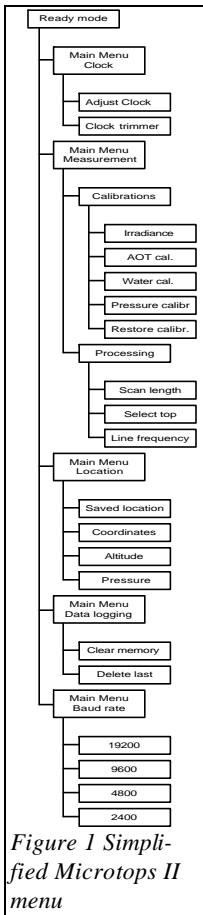

Figure 1 Simplified Microtops II menu

cape only if editing numbers). All settings accessible through the menu system are described in chapter 3 "Setup" on page 10.

When editing various settings the general rule is that ▲ or ▼ increment/decrement a selected (usually underlined) item while the ► and ◀ keys change the selection.

2.3 Before making first measurement

To measure the AOT, several MICROTOPS II settings must be properly initialized. These include:

1. Universal date and time (UT). By choosing UT for the timing of MICROTOPS II this setting is location-independent. The desired accuracy is ± 20 seconds. See "Setting the time and date" on page 10.
2. Geographic coordinates of the measurement site. Accuracy to a 5 minute angle is adequate for both latitude and longitude. See chapter 3.3 on page 18. The geographical coordinates can be picked off a map (scale 1:5,000,000 or larger), determined using a GPS receiver or obtained from a local meteorological office. The instrument's location is initially set for Philadelphia, PA.
3. Altitude of the measurement site. The altitude setting is not used in any calculations in the MICROTOPS II sunphotometer version. It exists for informational purposes only. See "Altitude" on page 20.
4. Atmospheric pressure at the measurement site. If the MICROTOPS II is not equipped with the optional barometric pressure sensor then the average station pressure can be used. If the pressure sensor is built-in then the station pressure should be set to 0000. Otherwise the user preset station pressure has precedence over the measured pressure. See "Pressure" on page 20.

Other settings should remain at their factory preset state. Changing these settings should only be attempted by experienced users having a full understanding of the inner workings of the device. In case a change is inadvertently made, the factory settings can be restored using the "Restoring factory calibration" function in the menu (see page 16). All settings are retained in the meter's non-volatile memory and are effective until the next change is made.

2.4 First measurement

Once the initial setup is completed the MICROTOPS II is ready to take measurements. The following steps outline the procedure:

1. Make sure that the top window cover of the MICROTOPS II is closed and then turn the instrument ON. When the display shows **RDY (ready mode)** you may open the top window cover.

2. Point the instrument's window towards the sun and adjust its position so that the image of the sun appears in the "Sun target". Center the image of the sun on the bull's-eye. Haze, thin clouds, and low Sun elevation may cause the Sun's image to appear dim or fuzzy. Thick haze and clouds will severely affect the measurement's values and increase their variability.
3. While keeping the sun's image centered, press the **Scan/Escape** button to initiate the scan. The meter will beep and the LCD will show:



The image shows a rectangular LCD display with a grey border. It contains two lines of text in a bold, sans-serif font. The first line reads "Scan 234" and the second line reads "Point at the sun".

The number in the top line is the count of the current scan including all the scans stored in MICROTOPS II's memory.

4. Aim the meter towards the sun until the instrument beeps twice and the display shows the **RDY** message. At that time the measurement is complete.
5. To view the measurement results press the **▶** button. The **▶** and **◀** keys will scroll through the parameters for an individual record (one scan or measurement). The **▲** and **▼** buttons change the selected record. Each record is identified by its date and time in the top LCD line. To go back to the **ready mode** press the **Scan/Escape** button. See "**Viewing the stored data**" on page 21 for more information.

3 Setup

3.1 Real time clock

The MICROTOPS II has an on-board real time clock and calendar (RTC) that provides time for the calculation of solar zenith angle. The software-driven clock trimmer enhances the long term accuracy of the clock. The current date and time is displayed in the **ready mode**. The settings of the clock, calendar, and clock trimmer can be modified from the keypad (chapter 3.1.1) or remotely via computer (chapter 4.2.6).

3.1.1 Setting the time and date

To set the RTC enter the menu by pressing the **Menu/Enter** button and then step 2 levels down by pressing **Menu/Enter** key twice (Figure 2).

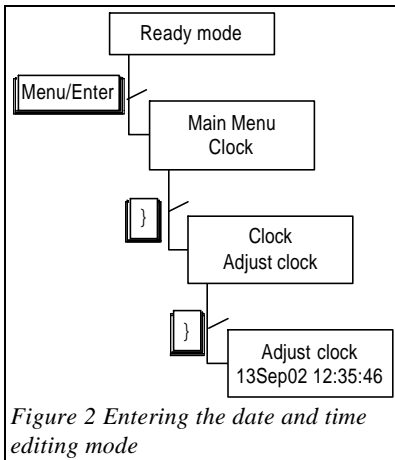

- Adjust clock -
13Sep02 12:35:46

The LCD will show the current date & time with the day item underlined by a cursor (see above). The selected (underlined) item may be incremented or decremented by pressing the **▲** and **▼** keys. The selection can be changed by pressing **▶** and **◀**. When incremented or decremented, each item will assume values from the range valid for that particular item. After setting the time press the **Scan/Escape** button 3 times to return to **ready mode**.

Please note that the MICROTOPS II uses Universal Time (UT) for all calculations. This time is defined by the Earth's rotation and determined by astronomical observations. The UT is related to the zero meridian which passes through the observatory in Greenwich, London. For water vapor and aerosol measuring purposes, this time can be considered equivalent to UTC (Coordinated Universal Time) since they do not diverge more than 0.9 seconds. Historically, the UT was called GMT (Greenwich Mean Time) and is being reported as such by some radio stations such as BBC. Another synonym for UTC is the "Zulu" time. This arises from the military custom of writing times as hours and minutes together and suffixed with a letter designating the time zone. For example, 2345Z = 23:45UTC ≈ 23:45UT.

The desired time accuracy for water vapor and aerosol measurements is 20 seconds. The Universal Time is broadcast by BBC radio stations. The UT can be also calculated knowing the offset between your Local Standard Time (LST) and UT, which is a constant for each time zone and for most places it is a whole hour multiple. For example, if your LST is 14:45:30 and your time zone is GMT-5 then

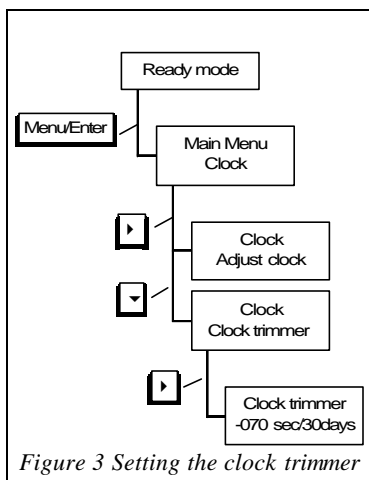

the UT is 9:45:30. Please note, that most countries use Daylight Savings Time during the summer season which is offset by 1 hour from LST.

3.1.2 Clock trimmer

The absolute accuracy of low power clocks is not adequate for long term time-keeping. Thus, a software "clock trimmer" was implemented into the MICROTOPS II. When given the clock's error in seconds per 30 days the algorithm periodically skips or adds 5 seconds effectively keeping the clock within 5 seconds from accurate time. The residual error would depend mainly on the storage temperature of the instrument. To calibrate the trimmer follow these steps:

1. Set the clock trimmer to 0 (see below) and set the clock to an accurate time (for example from a radio broadcast or GPS receiver).
2. Check the time a few days later (at least 5) and note the difference from the accurate time
3. Calculate the time drift in seconds per 30days. For example if the clock drifted 12 seconds ahead in 9 days (216 hours) then the clock drift per 30 days is:

$$30_day_drift = 30\ days * \frac{12\ seconds}{9\ days} = +40\ seconds$$

Setting the clock trimmer to the opposite of the clock drift, i.e. -40 seconds / 30 days would effectively correct the clock's error.

In order to set the clock trimmer enter the menu by pressing the **Menu/Enter** button, step 1 level down by pressing **▶** or **Menu/Enter**, press **▼** to select the **Clock trimmer** in the **Clock** menu and press **▶** or **Menu/Enter** to reach the trimmer editing (Figure 3). The display will show the current setting of the trimmer:

```

- Clock trimmer -
-070 sec/30days
  
```

One digit within the time correction will be selected (underlined) by a cursor. This digit can be incremented or decremented by pressing the **▼** and **▲** keys. The selection can be changed by pressing **▶** and **◀**. If the cursor points at the sign character then the **▼** and **▲** keys will toggle it between + and -. To go back to the **RDY** mode press the **Escape** key 3 times.

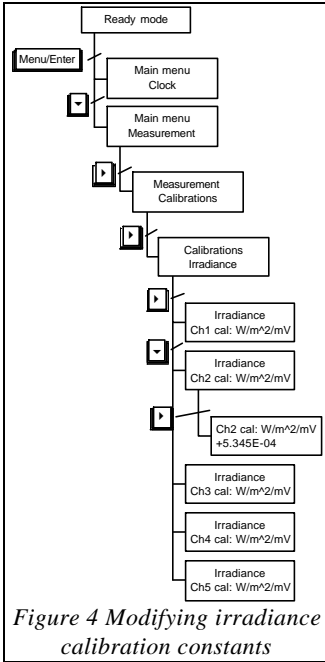

Figure 4 Modifying irradiance calibration constants

3.2 Measurement parameters and calibration constants

In order to measure the AOT, water vapor and irradiance the MICROTOPS II stores a set of calibration constants that relate the electrical signal measured by its A/D converter to the physical quantities desired. These constants are described in chapter "Calibration constants" that follows. Other important settings described in chapter 3.2.2 "Data processing" affect the measurement and data manipulation process.

3.2.1 Calibration constants

MICROTOPS II stores two sets of calibration constants: the **factory calibrations (FC)** and **user calibrations (UC)**. The **FC** are programmed into the instrument during the calibration process and cannot be modified by the user. The **UC** are initially set to equal **FC** but can be individually modified from the instrument's keypad should the user re-calibrate the instrument on his own. The **Restore calibrations** function copies **FC** into **UC** restoring the initial configuration of the instrument. The **UC** set can be read via serial port using function **X** in the remote control menu (See page 30).

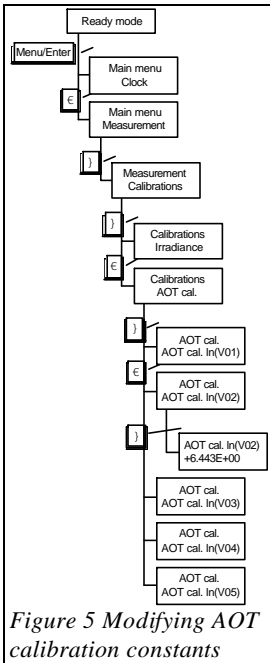

Figure 5 Modifying AOT calibration constants

3.2.1.1 Irradiance calibration constants

The calibration constants for irradiance link the measured signal in mV with the absolute radiometric power in W/m^2 of the direct solar radiation. The field of view of the MICROTOPS II is 2.5° , therefore larger than the solar disk's subtending angle. A small correction for the circumsolar radiation is taken into account when the meter is calibrated. All irradiance calibration constants are derived for the nominal filter bandwidth and its nominal center wavelength (see specifications for details).

There are 5 irradiance calibration constants C1-C5 corresponding to the nominal wavelengths of the instrument's filters. Each calibration constant can be individually modified from the keypad.

Figure 4 illustrates the menu path that leads to the editing of the irradiance calibration constant on channel 2.

Once the editing mode is reached the calibration constant is shown in exponential form (scientific notation):

Ch 2 cal: W/m²/mV
+ 5. 345E-04

In this notation, $5.345E-04 = 5.345 \times 10^{-4}$. The instantaneous irradiance in $[W/m^2]$ is calculated as:

$$IRRADIANCE_I = V_I * C_I$$

Where V_i and C_i are the channel's signal [mV] and irradiance calibration constant $[W/m^2/mV]$ respectively.

The selected (underlined) digit can be incremented/decremented with the \blacktriangle and \blacktriangledown keys and the selection can be changed with \blacktriangleright and \blacktriangleleft . The signs can be toggled between + and -. The exponent indicator E will be skipped automatically when changing the selection. Pressing the **Escape** key allows return to higher levels and to the **ready mode**.

The number will be automatically converted to its simplest form with the first digit always >0, except when the whole number is zero. For example 0.234E-04 will automatically become 2.340E-05. This way the best dynamic range for number editing is assured.

Please note that the absolute irradiance is not stored in memory after each measurement. Instead the raw data in mV is stored and the displayed irradiance is calculated based on the recorded voltage and current calibration constants. Consequently, a change in the irradiance calibration constants affects the irradiance values displayed on the LCD, but not the AOT and water vapor values.

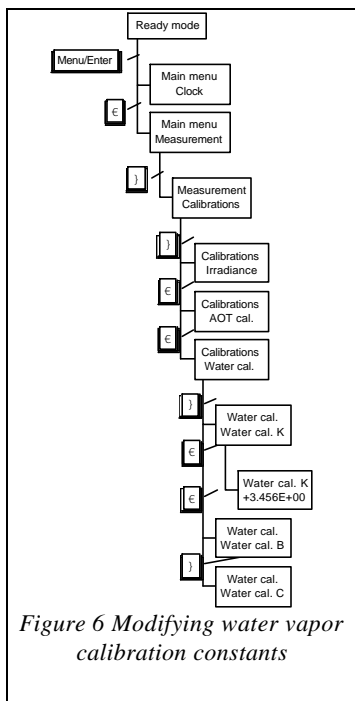

3.2.1.2 AOT calibration constants

There is an AOT calibration constant for each of the 5 channels of the MICROTOPS II. These constants represent the natural logarithm of the theoretical signal in [mV] adjusted to mean Earth-Sun distance each channel would read at the top of the atmosphere (airmass 0). Due to the obvious difficulties of calibrating a MICROTOPS in space the calibration constants are determined in a slightly less harsh environment. The extraterrestrial signals are derived either by Langley plot method at the Mauna Loa Observatory on Hawaii or by simultaneous comparison with a reference sunphotometer that was calibrated at Mauna Loa. The 5 calibration constants involved in the AOT calculation are:

$\ln(V01)$ - the natural logarithm of the extraterrestrial constant for channel 1 (for mean sun-earth distance)

$\ln(V02)$ - the natural logarithm of the extraterrestrial constant for channel 2 (for mean sun-earth distance)

$\ln(V03)$ - the natural logarithm of the extraterrestrial constant for channel 3 (for mean sun-earth distance)

$\ln(V04)$ - the natural logarithm of the extraterrestrial constant for channel 4 (for mean sun-earth distance)

$\ln(V05)$ - the natural logarithm of the extraterrestrial constant for channel 5 (for mean sun-earth distance)

The MICROTOPS II calculates the AOT value at each wavelength based on the channel's signal, its extraterrestrial constant, atmospheric pressure (for Rayleigh scattering), time and location. Solar distance correction is automatically applied. All optical thickness calculations are based on the Bouguer-Lambert-Beer law. The AOT formula is as follows:

$$AOT_I = \frac{\ln(V_{0I}) - \ln(V_I * SDCORR)}{M} - t_{RI} * \frac{P}{P_0}$$

Where the index "e" references the channel's wavelength, $\ln(V_{0e})$ is the AOT calibration constant, V_e is the signal intensity in [mV], **SDCORR** is the mean Earth-Sun distance correction, **M** is the optical airmass, $\hat{\rho}_{Re}$ is the Rayleigh optical thickness, and **P** and **P₀** are station pressure and standard sea-level pressure (1013.25mB) respectively.

The details of the calculations and calibration are presented in section "**Specifications**" on page 40.

Figure 5 shows the menu path to the AOT calibration constants. The number editing rules are described in chapter "Irradiance calibration constants" on page 12.

3.2.1.3 *Water vapor calibration constants*

The calibration constants for water vapor calculation include:

K - a constant dependent on the spectral transmission of the channel 936 nm filter

B - a constant dependent on the spectral transmission of the channel 936 nm filter

C - correction factor between aerosol optical depth at 1020 or 870 and 936 nm

If the 936 nm channel is present along with either 870 or 1020 nm then the water vapor calculation can be made based on the extraterrestrial constant of the 936 nm channel, its signal, time, location, water vapor calibration constants (K, B, and C) and AOT at 936 nm estimated from the neighboring channels. In the present version the AOT at 936 nm is defined as the mean of the AOT at 870 and 1020 nm channels (if both are present), as $AOT_{1020} * C$ if only 1020nm exists, or as $AOT_{870} * C$ if only 870 nm exists. The C constant is the third water vapor calibration constant. For standard US atmosphere C is 1.16 or 0.91 for 1020 nm and 870 nm respectively.

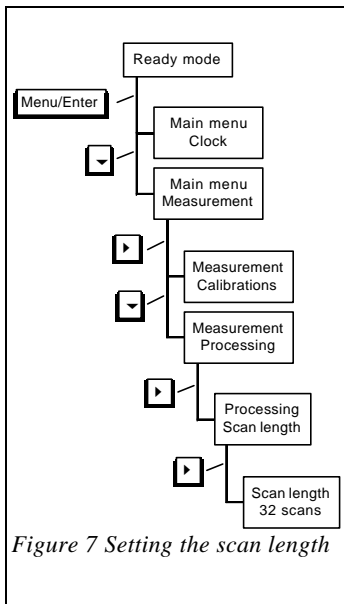

Figure 7 Setting the scan length

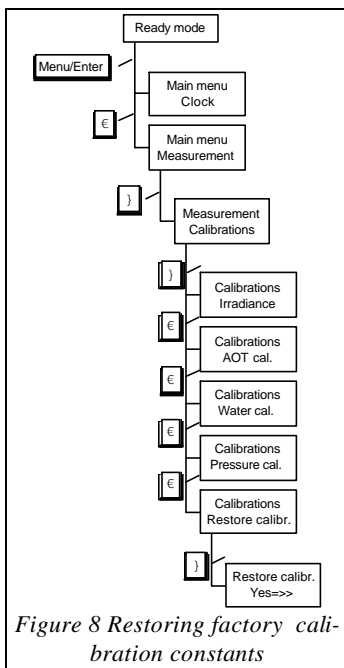

Figure 8 Restoring factory calibration constants

The water vapor calculation is based on a form of the Bouguer-Lambert-Beer law for the 936 nm channel, which is located in the water vapor absorption band. The water vapor column in [cm] is calculated as follows:

$$W = \left(\frac{\ln(V_{0w}) - \ln(V_w * SDCORR) - t_{aw} * M}{K * M^B} \right)^{1/B}$$

Where the index “w” references the 936 nm water vapor channel, $\ln(V_{0w})$ is the AOT calibration constant, V_w is the signal intensity in [mV], **SDCORR** is the mean Earth-Sun distance correction, **M** is the optical airmass, δ_{aw} is the aerosol optical depth, and **K** and **B** are the water vapor calibration constants.

Detailed description of the algorithms and calibration procedure can be found in "Theory of operation" on page 41.

Figure 6 shows the menu path for editing of the water vapor calibration constants. The number editing rules are described in chapter "Irradiance calibration constants" on page 12.

3.2.1.4 Pressure calibration constants

A solid state pressure sensor is built-in to the MICROTOPS II. This type of pressure sensor is characterized by very good linearity and stability but the repeatability of the sensor manufacturing process is poor therefore each sensor needs individual calibration. The MICROTOPS II sensor is factory calibrated in a pressure chamber with a 2-point calibration procedure. Ignoring the temperature compensation algorithm, the formula used to calculate pressure in [mB] from the sensor's voltage is:

$$PRESSURE = PSCALE * (V - POFFS)$$

Where **V** is the signal from the sensor in [mV], **PSCALE** and **POFFS** are the pressure calibration constants in [mB/mV] and [mV] respectively.

The two calibration constants PSCALE and POFFS are accessible through the menu system. Changing them is not advised since special equipment is needed for proper calibration.

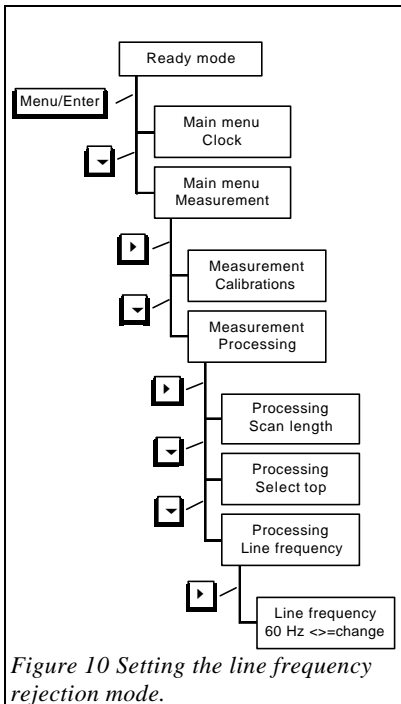
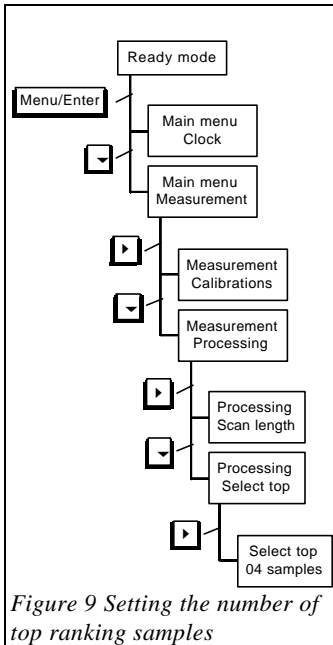

3.2.1.5 Restoring factory calibration

The factory calibration can be recalled in case a change is made that inhibits proper operation of the instrument. This operation restores all initial calibration constants and measurement settings.

The path to the restore screen is shown in Figure 8. The user is

```

- Restore calibr -
Yes = >>
  
```

presented with the following screen:

When the above screen is displayed the ► button triggers the restore operation. **Escape** or **Enter** buttons leave to upper menu level without restoring the calibrations.

The current calibration settings can be printed via the serial port using function X in the **remote menu** (see page 30).

3.2.2 Data processing

The settings that can be modified by the user include: scan length, the number of samples selected for averaging and the line frequency of the local power distribution system. The first two parameters are selected to suit most conditions and should not be changed except under special circumstances. Setting the local line frequency affects the internal digital filter's transfer function and enables elimination of line interference.

3.2.2.1 Scan length

In order to achieve best performance the MICROTOPS II is able to perform a series of rapid samples of all channels within one measurement scan. Processing a series of samples allows for the reduction of the error associated with sun targeting and the reduction of measurement noise. The effectiveness of the method implemented in MICROTOPS II is described in "**Theory of operation**" on page 41.

Each scan can consist of up to 64 samples from each of the 5 channels. The samples are taken in a rapid succession at a rate of over 3 samples/second (one sample contains readings from all 5 channels). Consequently, the maximum time

for a single scan is about 20 seconds. The number of samples in a scan (**scan length**) can be set by the user to a number from 1 to 64. The default value is 32 and it is suitable for virtually all conditions. Lowering the number of samples per scan may be necessary if only a short time is available for taking the measurement.

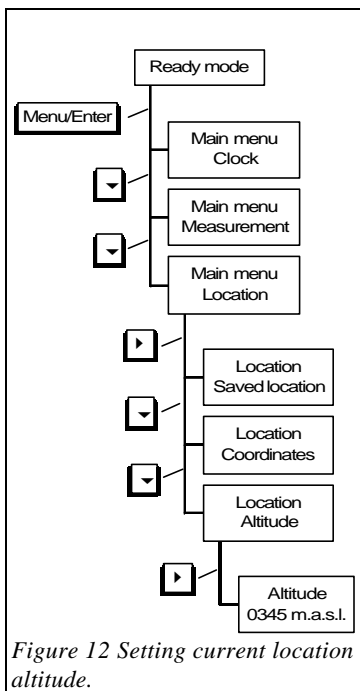
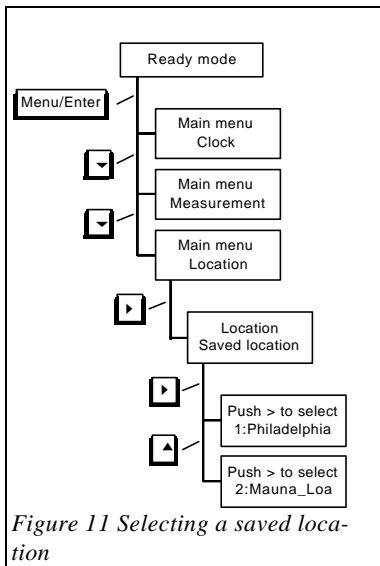

Figure 7 illustrates the path to scan length setting. The number editing rules are described in chapter "Irradiance calibration constants" on page 12. The instrument does not allow setting the scan length to a number lower than 1 or higher than 64.

3.2.2.2 Number of averaged samples

A signal strength factor is calculated for each sample based on the signal from all 5 channels. Only the samples with the highest ranking signal strength factor are averaged and passed for further processing.

The number of top ranking samples selected for averaging can be set by the user to a value between 1 and the scan length. If this number is equal to the scan length then all samples are simply averaged. If the scan length is modified so that it is less than the number of top selected records then the number of top selected records is automatically lowered to match the scan length.

The default setting of 4 samples selected for averaging is good for most conditions. The following special circumstances may justify changing this setting:

- Very large optical airmass and weak signal (less than 1mV). Increasing the number of averaged samples to maximum reduces the noise level of the measurement.
- A need to make a rapid measurement series. Decreasing both the scan length and number of selected samples will speed-up the measurement process.

To change the number of samples selected for averaging follow the path illustrated in Figure 9. The number editing rules are described in chapter "Irradiance calibration constants" on page 12. The instrument does not allow this setting to be lower than 1 or higher than scan length.

3.2.2.3 Line frequency

The most common source of interference in sensitive electronic equipment is the electromagnetic radiation emitted from power distribution lines. The radiation is emitted at the basic line frequency (60Hz in the US, 50Hz in Europe) as well as at harmonic frequencies (multiples of the basic fre-

**- Line frequency -
60 Hz <> = change**

quency). While the higher frequencies are effectively filtered out by the analog, low-pass filter, the basic and lower harmonics get to the input of the A/D converter with sufficient amplitude to distort readings. The A/D converter used in MICROTOPS II operates on the principle that discrimination against line frequency and harmonics is obtained by properly setting the digital filter coefficients.

The path to Line frequency setting is illustrated in Figure 10. After selecting the frequency selection window the user is presented with the following screen:

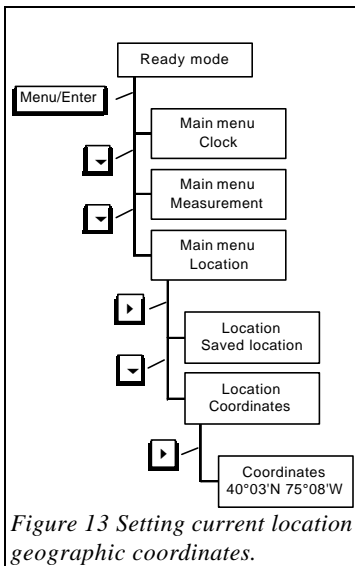

Pressing **▶** or **◀** toggles the setting between 50 and 60 Hz. Setting an incorrect frequency will result in increased variability of measurements in an environment polluted with line emitted noise.

Pressing **Escape** traverses the menu structure in reverse order and brings control back to the **ready mode**.

3.3 Location setup

Setting the geographical coordinates of the measurement site is essential for AOT and water vapor measurement. The location is subsequently used along with the time in a routine that calculates the solar zenith angle and airmass during measurement. The currently active settings are stored in a current location buffer. The current location buffer can be viewed and edited from a remote computer via serial port (chapter 4.2.1).

Valid ranges for location parameters are as follows:

Longitude:	(-180, +180>	Latitude:	<-90, +90>
Altitude:	(-1000, +20000)		
Pressure:	<0, 1100)		

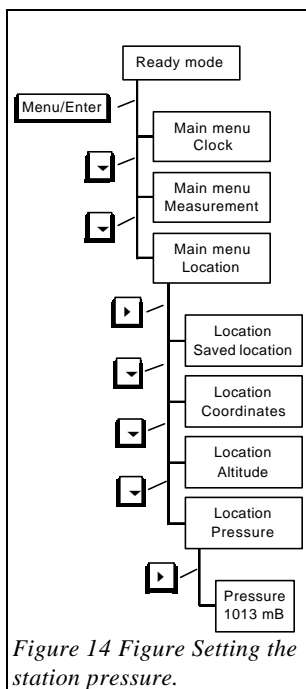

3.3.1 Saved locations

In addition to the current location buffer the MICROTOPS II contains an internal database of 6 named locations that can be programmed from a PC via the serial port (chapter 4.2.3). Any location record from the database can be quickly copied to the current location buffer using the "Saved location" feature. It facilitates the location setup when taking measurements in multiple locations. The additional bene-

**Push > to select
2:Mauna_Loa**

fit of naming locations is an option worth considering.

Please note that the database of saved locations cannot be modified from the instrument's keypad nor is the information for calculations fetched directly from this database. The location settings for calculations always come from the current location buffer. The "**Saved locations**" feature only copies a selected record (containing: coordinates, altitude and pressure) from the database to the current location buffer. The contents of the current location buffer can be edited from the keypad. All location parameters (except name) are stored with each measurement scan.

The menu path to selecting a saved location is shown in Figure 11. On the lowest level the user is prompted with the message:

The top line informs that pushing the **▶** key will copy the selected location parameters to current location buffer. The bottom LCD line shows the record number of the database location currently selected and the name of the location stored in it. There are 6 records in the database. Initially, some of them are named "Empty" and all location parameters are set to zero.

The selection can be changed by pressing the **▲** or **▼** key. The display will scroll through all the records. **In order to copy the location parameters it is necessary to press ▶ key when pointing at the desired location. Scrolling through the database does not modify the contents of the current location buffer.**

3.3.2 Coordinates

The geographic coordinates in the current location buffer can be modified from the keypad (Figure 13). The LCD will show:

**- Coordinates -
40°03'N 75°08'W**

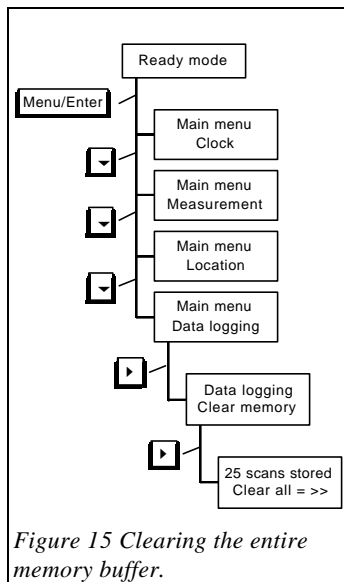

The selected (underlined) item can be incremented/decremented with the ▲ and ▼ keys and the selection can be changed with ▶ and ◀. The latitude and longitude directions will change N/S and W/E respectively. Pressing the **Escape** key allows return to higher levels and to the **ready mode**. The degrees (°) and minutes (1' = 1/60°) are modified independently. Please note that coordinates are sometimes given in degrees and decimal fraction of a degree. In that case proper conversion is necessary. An accuracy of a 5 minute angle is adequate for both latitude and longitude.

The change of coordinates is effective immediately. It will affect only measurements made after the change. Measurements already stored in the memory buffer will remain unaltered.

3.3.3 Altitude

The sunphotometer version of MICROTOPS II does not use the altitude setting in any of the calculations for AOT or water vapor column and therefore exists for informational purposes only.

However, the ozonometer version of MICROTOPS II, which is similar to the sunphotometer version but is configured with short ultraviolet filters in three of the five channels and algorithms for the derivation of the total ozone column, uses the altitude in the calculation of the radiation effective path (μ) through the ozone layer. Nonetheless, both versions of MICROTOPS II accept the altitude in meters above sea level (m.a.s.l.). The altitude in the current location buffer can be modified from the keypad (see Figure 12). When editing the altitude the number editing rules apply. The number editing rules are described in chapter "Irradiance calibration constants" on page 12.

3.3.4 Pressure

Atmospheric pressure affects the absolute optical path that the solar radiation must travel through before it reaches the instrument. Hence, it influences the Rayleigh scattering process and must be taken into account when calculating AOT. For most applications it is sufficient to enter a mean station pressure. MICROTOPS II accepts the pressure in milliBars (mB). The menu path is shown in Figure 14. The number editing rules are described in chapter "Irradiance calibration constants" on page 12. Pressing **Escape** after the number is set returns to upper menu levels. An accuracy of 10 mB is sufficient. Figure 16 shows how the station pressure changes with altitude. If the altitude is not known it can be estimated based on pressure measurement.

To facilitate measurements, the MICROTOPS II is equipped with a pressure sensor. To utilize the sensor, the pre-set station pressure must be set to zero. **If the pre-set station pressure is not zero it takes precedence over the sensor and the pre-set station pressure is stored and used for calculations.**

For unit conversion: $1 \text{ mB} = 0.0145 \text{ PSI} = 0.02953 \text{ in. Hg} = 0.1 \text{ kPa} = 0.75006 \text{ mm Hg}$

3.4 Data logging

MICROTOPS II has a non-volatile memory buffer for data storage. After each measurement scan one record is added to the buffer. If the memory space is filled then the "Memory full" message is displayed on the LCD and the last scan is ignored. To store additional records the memory buffer must be cleared (see "Clearing the memory buffer" on page 22) or some records must be deleted. The data from the buffer can be downloaded to a computer via the serial port (see "**Computer communication**" on page 25) or viewed on the LCD.

3.4.1 Viewing the stored data

The data **browse mode** allows inspection of all data stored in the instrument's non-volatile memory. The **browse mode** is initiated by pressing the ► key while in **ready mode**. The display shows:

12 Sep 02 16:45:56
AOT340 : 0.165

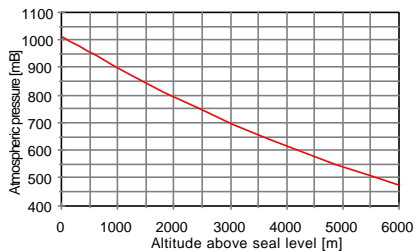

Figure 16 Mean barometric pressure vs. altitude

The LCD acts as a single cell window into a large imaginary spreadsheet (Figure 17). The top LCD line indicates the date and time of the selected record. The bottom line shows the name of the parameter and its value. Upon entering the **browse mode** the window is positioned in the upper left corner of the spreadsheet, showing the AOT of channel #1 from the last stored scan.

The window can be moved through the spreadsheet with the ▲ ▼ ▶ and ◀ keys. The ▶ and ◀ keys change the displayed parameter within one record while the ▲ and ▼ keys scroll the window between records showing the value of the selected parameter in other records (other scans). The top LCD line always shows the date and time so the record can be easily identified.

The displayed normal direct irradiance is not stored in memory. Instead, it is calculated on the fly when displayed on the LCD based on the raw data (in mV) and the C1...C5 calibration constants (in W/m²/mV) described in "Calibration constants" on page 12). Pressing **Escape** terminates the browse mode and brings the control back to **ready mode**.

3.4.2 Clearing the memory buffer

The instrument's data buffer can be cleared from the keypad as well as from the PC (see "**Remote control**" on page 26). The menu path to the clear memory function is shown in Figure 15. The user is presented with the screen:

The diagram shows a simulated LCD screen with a data table. At the top center, there is a double-headed arrow with a dashed line between them, indicating horizontal navigation. The table has columns for parameters: AOT870, AOT936, AOT1020, Water, and an ellipsis (...). The rows represent individual records with a date and time on the left, and values for each parameter. A vertical double-headed arrow on the left side of the table indicates vertical navigation between records. The current record is highlighted with a downward-pointing triangle (▼) to its left.

	AOT870	AOT936	AOT1020	Water
▲ ▪ 12Sep02 16:45:56	0.019	0.019	0.018	0.84	
▪ 12Sep02 16:45:40	0.018	0.014	0.010	0.83	
▼ 12Sep02 16:44:12	0.018	0.013	0.009	0.84	
12Sep02 16:43:38	0.019	0.015	0.012	0.87	
....					

Figure 17 Viewing the stored data on LCD

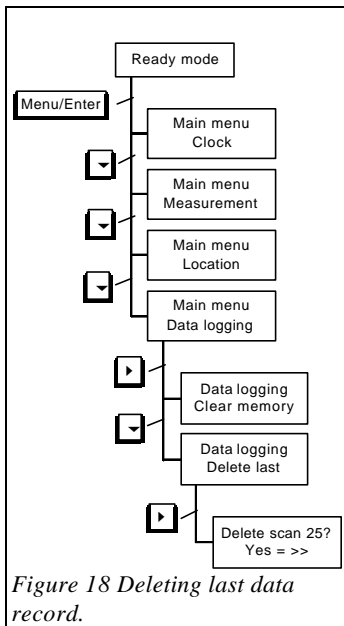

The top line shows the number of data records (scans) currently in memory. The bottom line informs that pressing **▶** will clear the buffer and the number of stored scans will change to zero. To withdraw from the menu without deleting the data press **Escape** or **Enter** instead of **▶**.



3.4.3 Deleting last measurement

If there is reason to believe that the last measurement is invalid it can be deleted from memory using this feature. Figure 18 illustrates the menu path.



The LCD displays:

Table 1 Memory contents that can be viewed on the LCD.

Parameter	Description
AOT1, 2, 3, 4, 5	Aerosol optical thickness at each of the instrument's wavelengths
WATER	Water vapor column in [cm]
Irradiance1, 2, 3, 4, 5	Direct irradiance on a normal surface in [W/m ²] at each of the instrument's wavelengths
SZA	Solar zenith angle in degrees
AM	Optical airmass
SDCOR	Earth-Sun distance correction
Coordinates	Geographical coordinates of the measurement site in degrees and minutes
Alt	Altitude of the measurement site in meters above sea level
Pressure	Barometric pressure at the measurement site in millibars. Either the measured value from the pressure sensor or the pre-set station pressure (see "Pressure" on page 20)
Temp	Temperature of the internal optical block in degrees Celsius
RAW1, 2, 3, 4, 5	Raw data. Signal in [mV] from each wavelength channel

The top line indicates the number of scans currently in memory. Each **▶** key activation will delete one record from memory (last measured) and the displayed number will decrement by one.

To withdraw without deleting the data press **Escape** or **Enter**.

3.5 Baud rate

MICROTOPS II can communicate with a computer or GPS receiver via the serial port. The speed of that communication link is adjustable from 2400 to 19200 baud.

Please note, that the baud rate should be set to 9600 if the GPS receiver is connected to MICROTOPS II (see "GPS Communication" on page 36).

Setting the baud rate to a higher speed quickens the data transfer process and makes the instrument more responsive during remote setup. However, some slower computers might not be able to communicate reliably at the highest speed.

Figure 19 illustrates the menu path to the **baud rate adjustment**. The screen will display:

```

- Baud rate -
9600 incr/decr
  
```

The lower LCD line indicates the current setting of the baud rate. Pressing ▲ or ▼ will increase or decrease the serial port's speed. The choices available are: 2400, 4800, 9600 and 19200 bits per second.

Pressing **Escape** brings the control back to upper menu levels and **ready mode**.

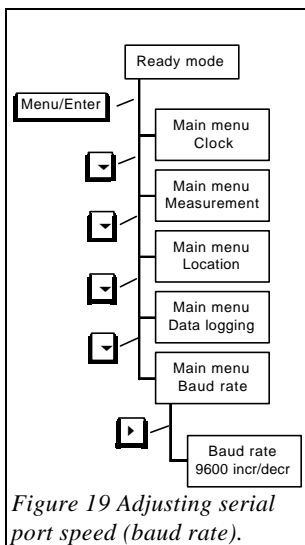

4 Computer communication

MICROTOPS II can communicate with a computer via RS232 serial port using the cable provided with the instrument. The data can be transferred from the instrument to the computer for archiving and processing. There are also a number of settings that can be inspected and modified remotely. An off the shelf communication software (Windows Terminal or HyperTerminal, Procomm, etc.) can be used to communicate with MICROTOPS II. However, the use of Microtops Organizer (page 31), a Windows based software that performs data management automatically, is recommended.

4.1 Physical connection

The cable connection between MICROTOPS II and the serial port is shown in Figure 20. The DB9

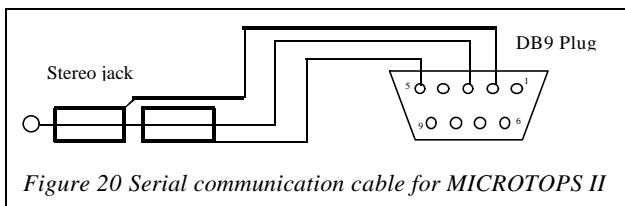

Figure 20 Serial communication cable for MICROTOPS II

plug should be connected to an available serial port on the back of the computer. The "stereo plug" should be inserted into the socket located on the side of MICROTOPS II.

If a third-party communication software is used then some minimal setup is necessary

in order to establish communication:

1. The serial port should be set to the one that MICROTOPS II is connected.
2. The baud rate of the MICROTOPS II and the computer's serial port must be the same (see "**Baud rate**" on page 24).
3. The port settings should be: 8 Data bits, 1 stop bit, no parity.
4. ANSI terminal emulation is recommended.

```
MICROTOPS II Ozone Monitor-Sunphotometer Ver. 5.5N/2003 S/N 07323
A - show current location
B - set current location
C - clear data buffer
L - list saved locations
M - modify saved location
P - print data buffer
S - initiate scan
T - set the date and time
X - print calibration constants
```

Figure 21 MICROTOPS II remote menu

4.2 Remote control

When the setup is completed turn the MICROTIPS II on and wait until the **ready mode** is reached (RDY on display). Press **Enter** on the computer's keyboard. The MICROTIPS II responds with the screen shown in Figure 21. The header contains the model, the software version number and the serial number of the instrument. The menu that follows is a set of functions that are triggered by pressing the associated key or combination of keys on the computer's keyboard.

4.2.1 Listing and setting current location

Code "a" or "A" sent to MICROTIPS II prompts the instrument to return its current location setup. The instrument returns:

```
Current location:
Lat(+N) Long(+E) Alt[m] Pres[mB] Loc#
 40.055 -75.131 137 0 256
```

The latitude and longitude are in degrees and decimal fractions thereof. North latitude and East longitude are positive, South and West are negative. Altitude in meters and pressure in millibars is followed by a number indicating whether the current location is copied from one of the saved and named locations (see "**Saved locations**" on page 19). If the location was set manually or from GPS the returned code is 256.

To set the current location from a PC press "b" or "B". MICROTIPS II replies with the following prompt:

```
Enter current location:
Lat(+N) Long(+E) Alt[m] Pres[mB] [Loc#]
±xx.xxx ±xxx.xxx ±xxxx xxxx [x]
```

If a valid location is entered following the pattern shown on screen the instrument will acknowledge acceptance of the settings with **OK**. If one of the values entered is beyond acceptable range then the message "Illegal value!" is returned. Too few numbers or incorrect pattern will result in an **Input ignored!** message.

Valid ranges for location parameters are as follows:

```
Latitude: <-90, +90>
Longitude: (-180, +180>
Altitude: (-1000, +20000)
Pressure: <0, 1100)
```

Changes in current location are effective immediately. All components of current location can be set individually from the keypad of the instrument.

Note: map coordinates in DEG:MIN:SEC format will have to be converted into their decimal formats before being entered.

In order to enable the internal atmospheric pressure sensor the station pressure entered must be set to 0.

4.2.2 Clearing data buffer

The instrument's buffer can be cleared from a computer by sending the "C" or "c" character. The MICROTOPS II responds with the prompt:

Clear data buffer? Y/N

Pressing "y" or "Y" confirms the deletion of the stored data from MICROTOPS II.

4.2.3 Listing and setting saved locations

The contents of the saved locations database (see "Saved locations" on page 19) can be customized from a PC via serial port. In response to a letter "I" or "L" pressed on the computer's keyboard the MICROTOPS II responds with the listing of all saved locations (Figure 22). The header identifies the printed parameters. North latitude is positive, south negative, east longitude is positive, west negative.

Saved locations:					
Loc	Name	Lat(+N)	Long(+E)	Alt[m]	Pres[mB]
1:	Philadelphia	+40.050	-075.133	20	1013
2:	Mauna_Loa	+19.533	-155.583	3397	680
3:	Empty	+00.000	+000.000	0	1013
4:	Empty	+00.000	+000.000	0	1013
5:	Empty	+00.000	+000.000	0	1013
6:	Empty	+00.000	+000.000	0	1013

Figure 22 Listing of saved locations database.

To modify any of the 6 locations press "m" or "M" on the PC's keyboard. The MICROTOPS II replies with the input pattern shown in Figure 23.

Enter the location parameters following the pattern displayed on the screen. First is a single digit number of the location that is being changed.

The maximum length of location name is 14 characters. Only alphanumeric characters (a-z, A-Z, 0-9) and underscore (_) are allowed within the name string. The coordinates are in degrees with decimal fraction (not minutes). Use a period to separate the fraction from the whole number. Two decimal places are sufficient for coordinates. The direction sign rules described above apply. The altitude is in meters and pressure in millibars. Altitude and pressure are stored as whole numbers (no fractions). Separate all items with one or more space characters and finish the entry with the CR character (Enter or Return on the key-

Enter new location:					
Loc	Name	Lat(+N)	Long(+E)	Alt[m]	Pres[mB]
x	xxxxxxxxxxxxxxxx	+xx.xxx	+xxx.xxx	+xxxx	xxxx

Figure 23 Location input pattern.

board). If all parameters are accepted then the MICROTOPS II replies with "Location x saved" where x is replaced with the number of the location. Otherwise an "Input ignored!" message is returned.

The **Microtops Organizer** software offers an interactive way of updating the instrument's location database (see "Microtops Organizer Software" on page 31).

```

REC#0001{CR}
FIELDS: {CR}
SN,DATE,TIME,LATITUDE,LONGITUDE,ALTITUDE,PRESSURE,SZA,AM,SDCORR,TEMP,ID,SIG380,SIG500,SIG870,SIG9
36,SIG1020,STD380,STD500,STD870,STD936,STD1020,R380_500,R500_870,R870_936,R936_1020,AOT380,AOT500
,AOT870,AOT936,AOT1020,WATER{CR}
07323,09/18/2002,14:04:31,40.050,-75.133,20,1013,54.28,1.710,1.009,25.3,0,310.23,
395.03,994.34,462.90,819.45,0.004,0.005,0.006,0.003,0.007,0.7853,0.3973,2.1481,
0.5649,0.172,0.123,0.070,0.063,0.055,1.34{CR}
END.{CR}

```

Figure 24 Data transfer format. Long lines are wrapped around and a {CR} marker is placed where the carriage return character is sent.

4.2.4 Downloading the data buffer

Sending “p” or “P” to the MICROTUPS II triggers data transfer from the instrument's buffer. The transmitted data (Figure 24) is preceded by a header **REC#xxxx** where the **xxxx** is the number of records to be downloaded. The keyword **FIELDS** in the next line is followed by the list of field names that correspond to the structure of downloaded data. When the transmitted information is captured to a file and subsequently imported to a spreadsheet then these field names appear above the columns of data facilitating data management. The field names are also used by the Microtops Organizer software so any changes in data format are accommodated automatically.

The data fields are separated by commas and records are separated by CR characters. This format is accepted by most data processing programs. Use "comma-separated" format when importing the data. Table 1 contains detailed description of all fields in the downloaded data.

The transmission is ended by the keyword "END." followed by a CR character.

To save the transmitted data to a disk use the data capture feature of your communication software. Various programs use different ways of initiating data capture. Please refer to your program's manual for specific instructions.

4.2.5 Initiating a scan

A measurement scan can be initiated from a remote computer by sending the "s" or "S" character via serial port. This feature can be used to control the MICROTUPS II when mounted on a tripod.

4.2.6 Setting date and time

If the "t" or "T" code is received by the MICROTUPS II the instrument replies with the prompt for current universal date and time (UT):

```

Date & time (UT):
mm/dd/yy hh:mm:ss{ENTER}

```

If a valid date and time is entered following the displayed pattern then the internal clock is set to that time and the instrument replies with **"OK"**. If the entry is not valid then the MICROTOPS II will display an **"Invalid!"** message.

The internal clock can also be set from the keypad (see **"Setting the time and date"** on page 10).

Table 1 Contents of MICROTOPS II data buffer

Field	Comments
SN	5-digit serial number of the instrument with leading zeros
DATE	The universal date of the measurement
TIME	The universal time of the measurement
LATITUDE	The latitude of the measurement site in degrees
LONGITUDE	The longitude of the measurement site in degrees
ALTITUDE	The altitude of the measurement site in meters above sea level
PRESSURE	In millibars, either the preset station pressure or the measured pressure from the pressure sensor. (see "Pressure" on page 20)
SZA	Solar zenith angle in degrees. The SZA is 0 for overhead sun and 90° for sun on the horizon
AM	Optical airmass
SDCORR	Earth-Sun distance correction
TEMP	Temperature of the optical block inside the instrument in degrees Celcius
ID	User defined identification code (see " Menu structure " on page 7)
SIG1 SIG2 SIG3 SIG4 SIG5	Signals in [mV] from all 5 optical channels
STD1 STD2 STD3 STD4 STD5	Standard deviation of all sampled signals within a single scan from all 5 optical channels
R1_2 R2_3 R3_4 R4_5	Ratio of signals between channels 1_2, 2_3, 3_4, and 4_5
AOT1 AOT2 AOT3 AOT4 AOT5	Aerosol optical thickness from all 5 optical channels

4.2.7 Printing calibration constants

All user calibration constants (see "Calibration constants" on page 12) can be retrieved from MICROTOPS II by sending the "x" or "X" code. The instrument replies with the listing of current settings (Figure 25). Please note, that the user calibration constants are initialized at the factory and set equal to factory calibration constants.

```
Current calibration constants S/N:07323
LNV01=6.799E+00 LNV02=6.443E+00 LNV03=7.056E+00 LNV04=7.540E+00 LNV05=6.825E+00
C1=5.363E-03 C2=3.063E-02 C3=8.155E-03 C4=4.412E-03 C5=7.814E-03
K=7.847E-01 B=5.945E-01 C=0.00
POFFS=-1.302E+01 PSCALE=1.746E+01
```

Figure 25 Printout of MICROTOPS II calibration constants.

5 Microtops Organizer Software

5.1 Introduction

The purpose of the Microtops Organizer is to make the MICROTOPS II easier to use and more productive by providing software that handles data collection and instrument setup. First the data buffer is downloaded to the PC where it is permanently stored into a database in DBase IV format. The file, DATA.DBF, is located in the sub-directory to which the Microtops Organizer was installed. In addition, the software enables the user to set up locations for the instrument, change the name of a location in the database, and clear the instruments memory buffer.

5.1.1 Software installation

1. Insert disk#1 into a 3 1/2" floppy drive and run **setup.exe**. Microtops Organizer is also downloadable from Solar Light's website at www.solar.com/software/microtops/mtporg.htm
2. Connect the large end (9-pin) of the serial cable supplied with the MICROTOPS II to an available serial port on the back of the computer and the small end (phono jack) to the MICROTOPS II.
3. Turn the MICROTOPS II on.
4. Microtops Organizer is now ready to transfer data from the MICROTOPS II data buffer to your PC.

5.1.2 Communication setup

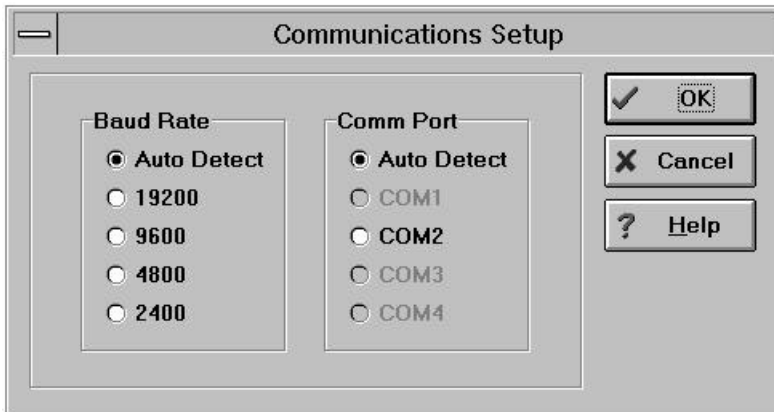

The serial port settings (comport and baud rate) can be adjusted using the **Communications** command in the Options menu. The default settings are **Auto Detect** for baud rate as well as for com-

port, which will automatically detect the appropriate port and baud rate for communication with the MICROTOPS II. If the comport and baud rate are not going to be changed, fixed settings can be selected instead of the auto detection process.

5.2 Microtops Operation

5.2.1 Downloading data

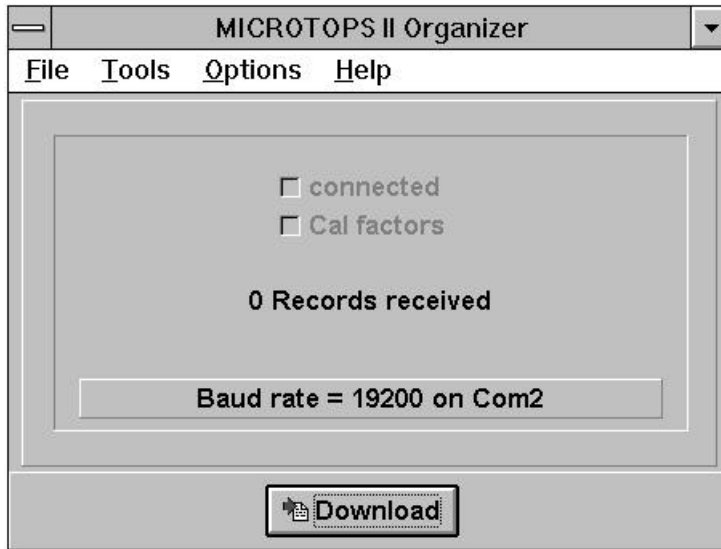

Downloading of data is accomplished by clicking the **Download** button on the bottom center of the main window. Be sure that the MICROTOPS II is connected to the PC with the supplied cable and is turned on. After clicking the **Download** button, the contents of the MICROTOPS II data buffer will be copied into the DATA.DBF database located in the PC.

5.2.2 Clearing the data buffer

The data buffer of the MICROTOPS II can be cleared by selecting the **Clear Buffer** command in the Tools menu. The user will be prompted to make sure that the data buffer should be cleared.

5.2.3 Modifying stored MICROTOPS II locations

Loc	Name	Lat(+N)	Long(+E)	Alt(m)	Pres(mB)
1	Philadelphia	40.050	-75.133	20	1013
2	Mauna_Loa	19.533	-155.583	3397	680
3	Empty	0.000	0.000	0	0
4	Empty	0.000	0.000	0	0
5	Empty	0.000	0.000	0	0
6	Empty	0.000	0.000	0	0

Retrieve Set Close Help

The MICROTOPS II internal location database (max. 6 locations) can be viewed and changed by selecting the **Change Instrument Locations** command on the Tools menu. Only legal values will be accepted by the MICROTOPS II. The **Retrieve** button will display all locations stored in the instrument. To change the location setting, type in the new data on the appropriate line and click the **Set** button. All of the displayed locations will be saved to the instrument for future use.

5.3 Database Operations

5.3.1 Changing location names in the computer database

Change Database Location Names

Latitude Longitude

Location Name ↓ -> To ↓

[598] Records Found

SN	DATE	TIME	LOCATION	LATITUDE	LONGITUDE
0	9/25/96	4:23:05 PM	Mauna_Loa	19.533	-155.583
3103	8/20/96	1:31:19 PM	Mauna_Loa	19.533	-155.583
3103	8/20/96	1:31:29 PM	Mauna_Loa	19.533	-155.583
3103	8/20/96	1:48:14 PM	Mauna_Loa	19.533	-155.583
3103	8/20/96	1:48:23 PM	Mauna_Loa	19.533	-155.583
3103	8/20/96	1:48:32 PM	Mauna_Loa	19.533	-155.583
3103	8/20/96	1:48:41 PM	Mauna_Loa	19.533	-155.583

Database locations can be changed by selecting the **Rename Database Locations** command in the Tools menu. A new window will appear. Before changing the location names, the correct data points must be selected in the database. To select data points, select the location name that is to be corrected (select <blank> for empty location names) and optionally type in the latitude and longitude of the location, and click the **Run Query** button. All of the data points defined by the above criteria will be displayed in the query results table at the bottom of the window. If the correct set of data points are in the query results table then the location names are ready to be changed. Select or type in the new location name and then click **Update**. The new location names will be written to the database.

5.3.2 Importing text files

MICROTOPS II data can be imported from an ASCII text file with the following format:

1. Calibration Constant Header
2. Data

A communications software such as Windows HyperTerminal or Procomm can create a file with the required data format. The basics steps are:

1. Setup communications protocol (comport and baud rate)
2. Start a log file with a “*.txt” extension.
3. type “X” to retrieve the calibration constant header
4. type “P” to download the data
5. close the log file

This log file can now be imported into the database by using the **File: Import command**. An open dialog will appear to select the text file (log file) to import into the database. After selecting the appropriate file with a “.txt” extension, click “OK”. The data will be imported into the database.

5.3.3 Importing files in data exchange format

Database text files can be imported into the database by using the **File: Import command**. An open dialog will appear to select the database text file to import into the database. After selecting the appropriate file with a “.dbt” extension, click “OK” and the data will begin to be inserted into the database.

5.3.4 Exporting in data exchange format

Database files can be exported to a database text file by using the **File: Export command**. A Save dialog will appear to select the database text file to export to. After selecting or typing the appropriate file with a “.dbt” extension, click “OK”. The data will be exported to the database text file.

5.3.5 Data description

Every data entry in the database has a data description field that can be used as a user description for the data. This field is a 40-character text field that can contain any text the user wishes to store with the data. Some uses include the date the data was downloaded or the name of the person who collected the data. Every download will result in a prompt for a data description entry in which the user can type. This prompt can be disabled by un-checking the **Data Description Prompt** in the Options Menu.

6 GPS Communication

Accurate location parameters can be automatically transferred from a GPS (Global Positioning System) receiver to the MICROTOPS II. The receiver determines location based on a combination of signals emitted from satellites orbiting the Earth. For commercial use the typical accuracy of GPS positioning is 30 meters. Any GPS receiver supporting NMEA 0183 formats versions 1.5 and 2.0 can be read by MICROTOPS II.

6.1 Setting up GPS

The individual setup procedures vary between receivers. The following example is based upon Garmin Model GPS 12 receiver:

1. Turn the GPS receiver ON
2. Turn the MICROTOPS II ON and set the baud rate to 9600. This is the only MICROTOPS II setting required for GPS compatibility.
3. Connect the MICROTOPS II and GPS receiver using the special cable provided by Solar Light Co. for the GPS option.
4. Go to the **MAIN MENU** page on the GPS by pressing the **PAGE** button.
5. Using **▲** and **▼** buttons on the GPS select **SETUP MENU**.
6. Press **ENTER** to view the **SETUP MENU** then **▼** to select **INTERFACE**.
7. Press **ENTER** then **▼** to select the interface mode. Press **ENTER** again to edit the mode and using **▲** and **▼** set it to **NONE/NMEA**.
8. Press **ENTER** then **▼** to select the baud rate. Press **ENTER** again to edit the baud rate and using **▲** and **▼** set it to **9600 baud**.
9. Press **ENTER** when done and return to the page showing satellite signal strength by pressing **PAGE**.
10. Position the GPS receiver so the view of the sky is not obstructed and the instrument can acquire the satellite information. This process may take up to several minutes depending on the satellite configuration and recent location changes. Please refer to the GPS manual if the receiver is not able to acquire position.
11. Once the position is acquired the GPS receiver shows 2D NAV message if the latitude/longitude is fixed based on the previous altitude information. The 3D NAV message appears when the GPS is able to calculate the altitude as well.
12. As soon as the location fix is available the GPS receiver sends this information to the Microtops II via the serial port. The Microtops II acknowledges reception of valid latitude, longitude

and time information by sounding the buzzer 3 times. Usually a new fix is sent every 2 seconds and the buzzer will sound again. The on-board clock of the Microtops II is automatically synchronized with the accurate time broadcast by GPS satellites.

13. Garmin GPS also sends the altitude information if in the 3D NAV mode. This information is specific to Garmin only since it is not included in the NMEA standard. Microtops II will acknowledge the reception of altitude information by sounding the buzzer 2 times.
14. If all components are received simultaneously (latitude, longitude, time and altitude) then the buzzer will beep 5 times (3 beeps immediately followed by 2).
15. When the complete information is sent to Microtops II the GPS receiver can be turned off and disconnected from Microtops II.
16. The GPS receiver does not provide local pressure and this setting is not changed by the GPS. If the Microtops II is equipped with an optional pressure sensor then leaving the station pressure at 0 will enable the pressure measurement. Otherwise the station pressure has to be updated manually.

Once the GPS is set up for NMEA support it remembers the setting and the whole operation is reduced to turning both instruments on, linking them with the supplied cable and waiting for 3 or 5 beeps from Microtops II.

7 Maintenance

As with any optical instrument the Microtops II needs to be handled carefully and periodic maintenance is necessary for best operation.

7.1 *Cleaning and storage*

To assure long term stability the instrument should be stored in a dry, dust-free place, preferably at room temperature. Condensation of water may damage the instrument when exposed for a prolonged period of time. It is recommended that the instrument be stored in its carrying case.

Microtops II should be protected from excessive vibrations and shock. The hard carrying case with soft foam lining or field carrying case should be used for transportation. If the instrument was exposed to shock (was dropped) it should be examined carefully and compared with another reference instrument. Re-calibration might be necessary.

The front quartz window should be kept clean. The window cover should be closed at all times except during measurement. Touching the window with your skin will leave an oily residue that will affect the measurements. The recommended method for cleaning the window is to use a Q-tip to push any lint or dust to one side then remove it with a stream of compressed gas. **As a last resort only**, pure alcohol (either isopropyl or ethyl) can be used to remove any residue from the window.

7.2 *Battery maintenance*

Microtops II operates on four **AA alkaline** batteries. A new set of batteries will last for at least 50 hours of continuous operation. Since the measurement requires very little time the effective battery life can be several months. Note that AA NiCad batteries will not provide sufficient voltage to run the Microtops II.

Low battery voltage sensing is built into Microtops II. The battery is checked upon power-up and every minute thereafter. If the battery voltage is or falls below a pre-set minimum the message "**Battery low - Enter = continue**" is displayed. Pressing **Enter** resumes operation and no more warning will be displayed until the next power-up cycle. The instrument will continue to function for a while, however measurement accuracy might be degraded.

To replace the batteries the cover of the battery compartment should be pulled towards the bottom and lifted up. Pay attention to the polarity of all batteries when replacing them.

7.3 *Calibration*

To assure reliable readings the Microtops II should be re-calibrated yearly and, if possible, participate in inter-comparisons with other sunphotometer instruments. The calibration procedure is described in "**Theory of operation**" on page 41. An experienced user on a very clear day having access

to a site with an unobstructed view of the sky for an entire morning can attempt the calibration of the AOT and water vapor measurements.

Calibration of the irradiance can be performed by direct comparison of Microtops II with a reference sunphotometer. The calibration of each channel assumes the nominal bandwidth of that channel's filter and the respective nominal center wavelength (see "Specifications" on page 40). For example the reading of a 380 nm channel corresponds to the direct component of the irradiance on a normal surface within a band of 378 – 382 nm.

8 Specifications

Optical channels	340 ± 0.3nm, 2.0 ± 0.4nm FWHM 380 ± 0.4nm, 4.0 ± 0.6nm FWHM 440 ± 1.5nm, 10.0 ± 1.5nm FWHM 500 ± 1.5nm, 10.0 ± 1.5nm FWHM 675 ± 1.5nm, 10.0 ± 1.5nm FWHM 870 ± 1.5nm, 10.0 ± 1.5nm FWHM 936 ± 1.5nm, 10.0 ± 1.5nm FWHM 1020 ± 1.5nm, 10.0 ± 1.5nm FWHM
Max. out-of-band sensitivity, relative to peak transmission	340nm: 10^{-6} < 650nm; 10^{-5} < 1000nm 380nm: 10^{-6} < 650nm; 10^{-5} < 1000nm 440nm: 10^{-5} < 1000nm 500nm: 10^{-6} < 1100nm; 10^{-5} < 1200nm 675nm: 10^{-6} < 1100nm; 10^{-5} < 1200nm 870nm: 10^{-6} < 1100nm; 10^{-5} < 1200nm 936nm: 10^{-6} < 1100nm; 10^{-5} < 1200nm 1020nm: 10^{-6} < 1100nm; 10^{-5} < 1200nm
Angle of view	2.5°
Dynamic range	$> 3 \times 10^5$
Precision	0.001 AOT; 0.01cm Water vapor
Non-linearity	Max. 0.002%
Operating environment	0-50°C, no precipitation
Computer interface	RS232
Data storage	800 records
Power source	4xAA alkaline batteries
Battery life	50hrs min. continuous operation (10 min. inactivity shutdown)
Weight	21oz (600 grams)
Size	4"W x 8"L x 1.7"D (10 x 20 x 4.3cm)

The irradiance calibration factors are derived for the nominal FWHM and center wavelengths listed above.

9 Theory of operation

**Note: This section presents information about the ozonometer version of Microtops II however, much of the information applies to the sunphotometer version as well.*

Design, calibration and performance of MICROTOPS II hand-held ozonometer*

Marian Morys

Solar Light Co. Inc., Philadelphia PA 19126

Forrest M. Mims III

Sunphotometric Atmospheric Network, Seguin TX, 78155

Stanley E. Anderson

Westmont College, Santa Barbara, CA 93108

Abstract

MICROTOPS II, a 5-channel hand-held sunphotometer a narrow band filter for each channel was designed to allow quick and inexpensive measurements of the total ozone column and water vapor column. The 2.5nm FWHM for the UV channels was selected to balance noise and ozone measurement performance. The total ozone column is automatically calculated based on measurements at 3 UV wavelengths, the site's latitude and longitude, universal time, altitude and pressure. A built-in pressure transducer facilitates the measurement. Two IR channels allow measurement of total precipitable water in the atmosphere. Critical aspects of the design described in the paper include: stray light rejection, thermal and long term stability, signal/noise optimization, collimation, targeting and data analysis. MICROTOPS II performance is tested by comparing to Dobson spectrophotometers.

9.1 Introduction

Several attempts have been made to construct an inexpensive portable sunphotometer for the purpose of total ozone column measurement¹. In the past a major obstacle in producing accurate and repeatable results was the lack of stable, narrow band UV filters with adequate out-of-band rejection. Recent advances in thin film deposition techniques² made it possible to produce filters of satisfactory quality. The Total Ozone Portable Spectrometer (TOPS) project³⁻⁶ has proven that filters currently available can be used to measure the total ozone column accurately. Based on prior experience a new portable sunphotometer and ozone monitor was developed at Solar Light Company. The MICROTOPS II is a 5-channel portable sunphotometer measuring the direct solar radiation at 300, 305.5, 312.5, 940 and 1020 nm. Based on these measurements it is possible to calculate the total ozone column and total water vapor.

9.2 Basics of the instrument

Ozone absorbs shorter wavelengths of solar ultraviolet radiation much more than longer wavelengths. This means that the amount of ozone between the observer and the Sun is proportional to the ratio of two wavelengths of the Sun's ultraviolet radiation. MICROTOPS II uses that relationship to derive the Total Ozone Column (the equivalent thickness of pure ozone layer at normal pressure) from measurements of 3 wavelengths in the UV region. Similarly, as in the traditional Dobson instrument, the measurement at an additional 3rd wavelength enables a correction for particulate scattering and stray light. The field of view of each of the optical channels is 2.5° .

The precipitable water column is determined based on measurements at 940nm (water absorption peak) and 1020nm (little absorption by water).

Both the calculation of ozone column and precipitable water column require knowledge of the actual air mass. It is calculated by the MICROTOPS II based on the time from a built-in clock and the user-entered coordinates of the measurement site.

9.3 Instrument design

The overall structure of MICROTOPS II is shown in Figure 26. The optical block shapes the field of view of the instrument, filtering incoming radiation, detecting it and facilitating targeting of the sun. Electrical signals from the photodetectors are amplified, converted to digital form and numerically processed in the signal processing block.

9.3.1 Optical block

The success of the instrument depends on its ability to measure ozone column with long term stability under a broad range of air masses and atmospheric conditions.

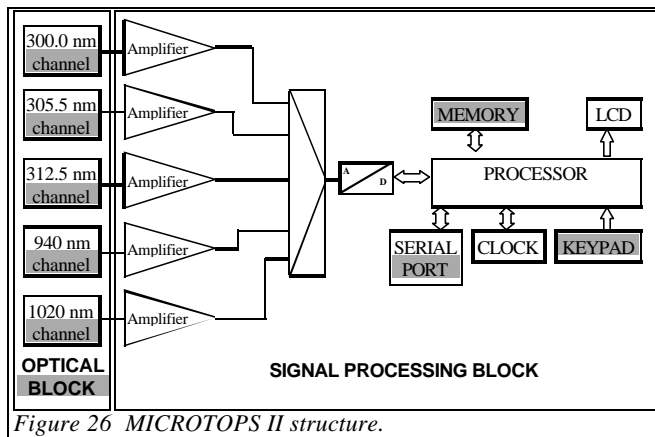

Figure 26 MICROTOPS II structure.

The entire instrument and all subsystems were analyzed in a series of computer simulations. The initial design goal of an overall precision better than 3%, for air mass up to 3, translated into a set of very stringent specifications. Several iterations of the process allowed us to find a set of specifications that met the initial criteria and were realistic at the same time.

Described below are some of the critical issues considered during the design process:

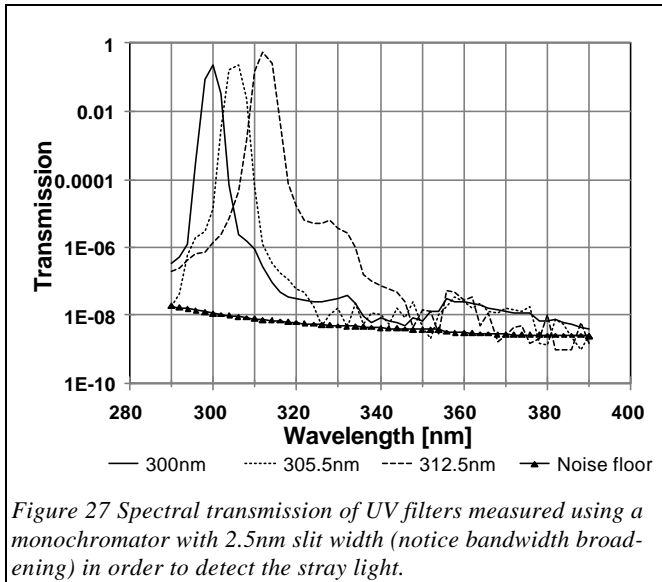

Figure 27 Spectral transmission of UV filters measured using a monochromator with 2.5nm slit width (notice bandwidth broadening) in order to detect the stray light.

- To assure long term stability the optical block is machined from a cast aluminum plate.
- The mechanical alignment of the optical channels is better than 0.1°.
- Internal baffles in each channel prevent reflections from reaching the photodetectors. The internal surfaces of the collimators are lined with a low-reflectivity material.
- The sun-targeting hardware is machined from aluminum and directly attached to the filter block to avoid temperature effects on targeting.
- The entire optical block is suspended in the enclosure in such a way that a mechanical strain applied to the enclosure does not result in substantial

strain in the optical block.

- The sun targeting assembly is laser-aligned to within 0.1° from the optical axis of the block.
- The temperature of the optical block is monitored and logged in order to allow temperature compensation if needed.
- A built-in solid state pressure sensor provides the current atmospheric pressure needed for the

Table 2 UV filters specifications

	FILTER 1	FILTER 2	FILTER 3
Center Wavelength	300nm ±0.3nm	305.5nm ±0.3nm	312.5nm ±0.3nm
FWHM	2.4nm ±0.4nm	2.4nm ±0.4nm	2.4nm ±0.4nm
Angle of incidence	0	0	0
Max. out of band transmission (relative to peak)	10 ⁻⁷ λ<650nm 10 ⁻⁵ λ>650nm	10 ⁻⁶ λ<650nm 10 ⁻⁴ λ>650nm	10 ⁻⁵ λ<650nm 10 ⁻⁴ λ>650nm
Min. peak transmission	15%		
Temp. coef. of center wavelength	<0.005 nm/°C		
Wet/dry shift	<0.1nm		
Long term stability	<0.1nm/year		
Operating environment	temp: -20 .. +50°C; hum: 0 ... 100%;		

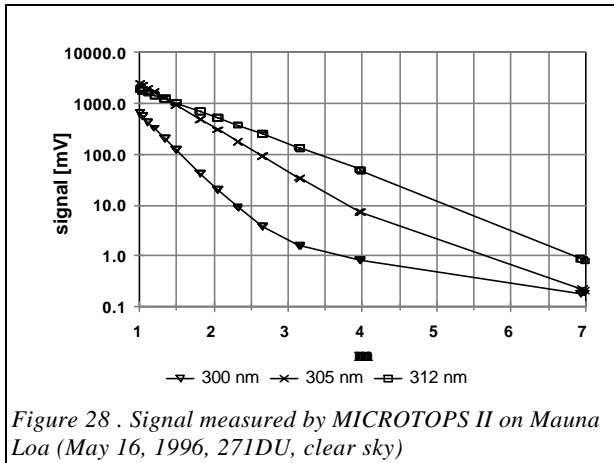

Figure 28 . Signal measured by MICROTOPS II on Mauna Loa (May 16, 1996, 271DU, clear sky)

Rayleigh scattering calculation.

Special consideration was given to the optical filters and photodetectors, particularly for the UV channels. The most critical, and difficult to meet, was the requirement for high out-of-band rejection. The computer simulation called for leakage no greater than 10^{-7} ($\lambda < 650\text{nm}$) for 300nm filters. Lower wavelength filters have more strict leakage requirements because the in-band signal is weaker than that at higher wavelengths. Typical shapes of the filters' transmissions are shown in Figure 27. The repeatability of center wavelength and FWHM within a batch was in the order of 0.1nm.

The novel technology for depositing the filter's layers and coatings assures long life and stability.

The GaP photodetectors used in the MICROTOPS II are characterized by relatively strong sensitivity in the UV region, low noise level and low sensitivity above 500nm. These characteristics allowed us to relax the out-of-band rejection above 650nm lowering the production cost of the filters. The photodetectors are hermetically packaged to assure long life and stability.

9.3.2 Signal conditioning and processing

The solar radiation at short UV wavelengths decreases rapidly with increasing air mass (Figure 28). The slope increases as the ozone layer increases. In order to measure the ozone column the MICROTOPS II measures each wavelength independently and then calculates the ratio, unlike the Dobson instrument, which benefits from the differential approach. In order to perform accurately, the MICROTOPS II must be able to measure very weak and very strong signals with adequate signal-to-noise ratio and high linearity. To achieve that goal the following approach was taken:

- The input amplification stages were optimized to have the lowest noise level. The dominant noise source in the most sensitive channels is the thermal noise of the feedback resistance in the amplifier. The band-width of all amplifiers is reduced to a minimum and is equal for all channels. With a band-width of just under 10Hz the max. RMS amplifier noise is $5.8\mu\text{V}$.
- A high performance sigma-delta A/D converter with on-chip digital filtering is used. The high over-sampling ratio of this converter eliminates the need for high-order anti-aliasing filters at the front-end. The conversion non-linearity is less than 0.0015% within the entire input range and the A/D conversion noise level is $5.3\mu\text{V}$ RMS with 2.5V full scale.
- The A/D converter's filter is programmed to reject line frequency interference (user selectable).

- Each measurement cycle comprises multiple measurements of all channels that are processed numerically in order to lower noise level and improve overall accuracy.
- Attention was paid to proper shielding and optimal layout of the amplifiers and the conversion block.

Overall, the dynamic range achieved in the instrument is over 300,000 with excellent linearity leaving adequate signal-to noise margins even for very weak signals.

To assure long term stability of measurements the electronic circuitry itself has to be very stable, both thermally and long term. The gain of the amplifiers is determined by a set of precision resistors with temperature coefficients below 0.005%/°C. The amplifier's offset is automatically compensated every time the instrument is powered on. Both the offset and full scale of the A/D converter are automatically calibrated before each scan. The full scale calibration relies on a high performance voltage reference with the temperature coefficient under 0.001%/°C and long term stability in the order of 0.005%/year.

Real time and date for the solar zenith angle calculation is provided by the on-board clock. The inherent accuracy of low-power crystal clocks is not adequate for long periods of time, therefore, a clock trimming mechanism is implemented in the software. The user can enter the clock correction in seconds/30 days and the program will periodically skip (or add) a few seconds in order to maintain the clock accuracy to within 5 seconds.

9.3.3 Sun targeting

While optionally equipped with the hardware for tripod mounting, the MICROTOPS II is designed primarily for hand-held operation. There was even concern about the accuracy of pointing the meter towards the sun. A series of tests indicated that in the hands of a well trained operator the instrument can move up to 1° off the sun's center. Presence of strong wind or cold weather may further degrade the steadiness of the operator's hand.

To enhance the sun targeting accuracy in the MICROTOPS II an algorithm was implemented that analyzes a series of rapidly repeated measurements. A signal strength factor is calculated based on the signal from all 3 UV channels. Only the records with highest ranking signal strength factor are averaged and passed for further processing. These are the records for the best positioning of the sun's image.

The total number of samples in a scan as well as the number of samples averaged can be set by the user.

Figure 29 presents the results of three consecutive series of ozone measurements performed on a fairly clear day, with the same instrument. Each of the measurement series employs a different sun targeting technique: hand-held with targeting enhancement based on a series of 32 rapid

Table 3 Performance of sun targeting methods.

Targeting method	Standard deviation
Hand-held, no enhancement	0.87%
Hand-held, enhanced	0.18%
Tripod mounted	0.23%

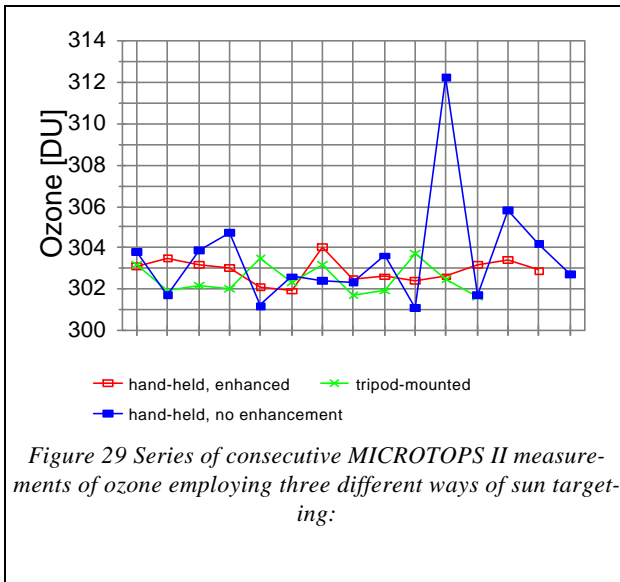

measurements (measurement time approx. 10 seconds), hand-held with just averaging of measurements and the third series was measured with MICROTOPS II mounted on a tripod.

Table 3 shows the standard deviation of each measurement series, the hand-held with targeting enhancement offering the most repeatable results with a standard deviation of 0.18%. The targeting enhancement produces results that are slightly better than tripod-mounted instrument since it compensates the targeting error due to limited resolution of the instrument's targeting system.

9.4 Calibration and measurement of ozone

Calibration of the MICROTOPS II instrument requires that the intensity of radiation measured at each channel be analyzed assuming the validity of the Lambert-Beer law, which when applied to ozone absorption and Rayleigh scattering by the atmosphere, gives the simple equation

$$\mathbf{I} = \mathbf{I}_0 e^{-\alpha \mu \Omega - m \beta P / P_0} \quad (1)$$

\mathbf{I}_0 is the intensity of the light of a particular wavelength before it passes through the atmosphere, \mathbf{I} the intensity remaining after all processes attenuating the incident radiation have occurred, \mathbf{W} is the amount of ozone, \mathbf{a} is the ozone absorption coefficient at that specific wavelength, \mathbf{m} the ratio of the actual and vertical path lengths of the radiation through the ozone layer, \mathbf{P} is the pressure of the atmosphere in mB, \mathbf{P}_0 is standard pressure = 1013.25 mB, and \mathbf{m} is a quantity known as the airmass, which is defined as the ratio of the actual and vertical path lengths of the radiation through the entire atmosphere to the detector. For $\mathbf{m} < 2$ the \mathbf{m} and \mathbf{m} are virtually identical. Other processes including molecular scattering (Rayleigh scattering coefficient represented by \mathbf{b}) by the atmosphere, and particulate scattering produced by haze (water plus atmospheric pollutants of micron particle size) are included as shown into the exponent for a complete representation of atmospheric attenuation. It is customary to ignore the particulate scattering. Studies have shown that even the worst haze conditions do not effect ozone measurements by more than a few percent and much less under usual conditions.⁷

Expressions for μ and m quantities are as follows:^{8,9}

$$m = \sec Z - 0.0018167 \cdot (\sec Z - 1) - 0.002875 \cdot (\sec Z - 1)^2 - 0.0008083 \cdot (\sec Z - 1)^3 \quad (2)$$

$$m = \frac{R + h}{\left[(R + h)^2 - (R + r)^2 \sin^2 Z \right]^{1/2}} \tag{3}$$

or more conveniently,
$$m = \frac{1}{\sqrt{1 - v \cdot \sin^2 Z}}, \tag{4}$$

where v is a geometric factor for the height of the ozone layer given by

$$v = \frac{(R + r)^2}{(R + h)^2}, \tag{5}$$

R = mean earth radius (6371 km),

r = height of ozone station above sea level in km

and h = height of ozone layer above sea level approximated as :

$$h[km] = 26 - 0.1 \cdot latitude [^\circ] \tag{5a}$$

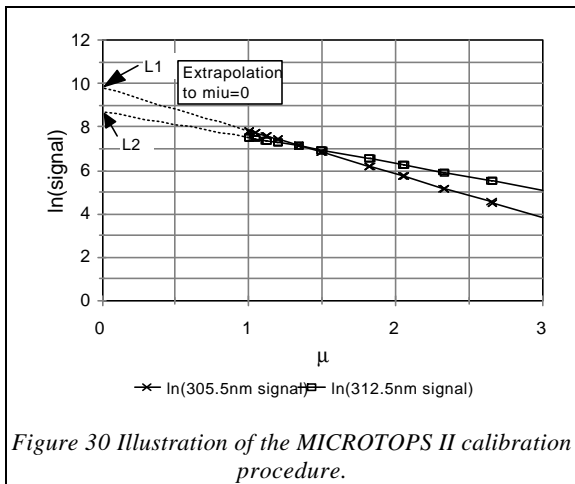

In general, at sea level in the continental United States, $v = 0.99316$.

The solar zenith angle Z (angle of sun with respect to the zenith), which is the basis for the calculation of i and m is calculated, based on the coordinates of the measurement site and universal time (UT). The algorithm implemented in the MICROTOPS II were tested¹⁰ to an accuracy of $\pm 0.03^\circ$ (max. error) for the entire practical range of latitudes and longitudes, for the time period of 1996-2006. The error observed comes partially from simplified algorithms and partially from

the use of single-precision arithmetic. This error causes negligible effect on ozone calculations. The MICROTOPS II is equipped with a real-time clock and calendar. The coordinates of the location are entered from the keypad, GPS receiver or an external computer.

The theoretical expression for the ozone value derived for any channel pair (indexed by 1 and 2 in this paper) is as follows:

$$\Omega(DU) = \frac{1000 \cdot \left[L_{12} - \ln\left(\frac{I_1}{I_2}\right) - \mathbf{b}_{12} \cdot m \frac{P}{P_o} \right]}{\mathbf{a}_{12} \cdot m} \quad (6)$$

where:

$\mathbf{a}_{12} = (\mathbf{a}_1 - \mathbf{a}_2)$, the difference in the ozone coefficients for respective channels 1 and 2

$\mathbf{b}_{12} = (\mathbf{b}_1 - \mathbf{b}_2)$, the difference in the air scattering coefficients for respective channels 1 and 2

$L_{12} = (L_1 - L_2) = \ln(I_{o1}/I_{o2})$, the combined "extraterrestrial constant" (Figure 30).

L_{12} corresponds to measurement of the incident radiation above the earth's atmosphere (no attenuation from any absorption or scattering process). It is obtained by extrapolating a plot (or doing a regression analysis) of $\ln(I_1/I_2)$ vs. μ (Langley plot). The ozone column thickness is expressed in Dobson units, which correspond to milliatm-cm.

Calibration was based on the Langley method, which has a long history of application to the Dobson instruments¹¹. A regression analysis is carried out using the most linear portion of Langley plot ($\mu < 1.75$) for each channel and the data is appropriately weighted. The intercept gives the extraterrestrial constant for that channel.

The α 's and β 's for each channel were calculated using a model developed by the TERC project¹². The exponential equation (1) when linearized gives an expression of the form:

$$\ln I = \ln I_o - \mathbf{a}\mu\Omega - \mu\mathbf{b}P/P_o \quad (7)$$

For $m \sim \mu$ it yields a value for $\ln(I_o)$ and a total coefficient value for the remaining terms when subjected to regression analysis. That constant must then be broken down into a term for ozone absorption and a term for the Rayleigh scattering.

Table 4 Effective wavelength vs. filter's center wavelength.

MICROTOPS II Filter's center wavelength [nm]	Typical effective wavelength I_o [nm]
300.0	300.8
305.5	306.0
312.5	312.6

TERC developed a simple model which assumed that a narrow bandpass filter acts like a filter of a single wavelength. This forces an additional constraint on the coefficients to be determined, because they must both be appropriate for that wavelength. Very helpful is the fact that the \mathbf{a} and \mathbf{b}

change differently with wavelength. To simplify the determination of \mathbf{a} and \mathbf{b} , the wavelength dependencies of these coefficients were calculated with the following two equations, derived by fitting the ozone cross sections derived by Molina and Molina¹³ and the Rayleigh coefficients of Penn-dorf¹⁴.

$$\mathbf{a}(\lambda) = (2.1349 \times 10^{19}) e^{(-0.14052 \lambda)} \quad (8)$$

$$\mathbf{b}(\lambda) = (16.407 - 0.085284 \lambda + 0.00011522 \lambda^2) \quad (9)$$

where λ is the wavelength in nm.

Substituting (8) and (9) into (7) one can calculate the slope \mathbf{D} of the $\ln \mathbf{I}$ vs. μ line:

$$\mathbf{D} = -1 * ((2.1349 \times 10^{19}) e^{(-0.14052 \lambda)} * \mathbf{W} / 1000 + (16.407 - 0.085284 \lambda + 0.00011522 \lambda^2) P/P_o) \quad (10)$$

The 1/1000 factor associated with \mathbf{W} comes from unit conversion between Dobson Units and atm-cm. The effective wavelength λ_o of each channel's interference filter is determined by finding the wavelength at which the slope of the \ln of the measured signal (Figure 30) matches the theoretical slope \mathbf{D} . The ozone column for calculation of \mathbf{D} is taken from a co-located independent instrument, such as Dobson spectrophotometer. Once the λ_o is known, the \mathbf{a} and \mathbf{b} for each channel can be calculated from (8) and (9).

For the filters used in MICROTOPS II the effective wavelengths are fraction of a nanometer above the filter's center wavelength (Table 4).

9.5 Derivation of water vapor

Water vapor transmission was studied for almost a century¹⁵. The calibration technique used for MICROTOPS was developed by Reagan et.al.¹⁶ and further tested by Michalsky et.al.¹⁷. The water vapor measurement is based on a pair of radiometric measurements in the IR band. The 940nm filter (10nm FWHM) is located in a strong water vapor absorption band, while the 1020nm filter (10nm FWHM) is affected only by aerosol scattering.

For the 940nm channel (indexed with 1) located in the water vapor absorption band the Bouguer-Lambert-Beer law takes the form:

$$\frac{V_1}{V_{01}} = \exp(-\mathbf{t}_{a1} m - k(um)^b) \quad (11)$$

where V_1 is the ground based radiation at 940nm, V_{01} is the extraterrestrial radiation, \mathbf{t}_{a1} is the aerosol scattering coefficient at 940nm, u is the vertical water vapor column thickness, m is air mass and k and b are constants numerically derived for the filter.

For the 1020nm channel there is negligible water vapor absorption and the equation takes the form:

$$\frac{V_2}{V_{02}} = \exp(-\mathbf{t}_{a2} m) \quad (12)$$

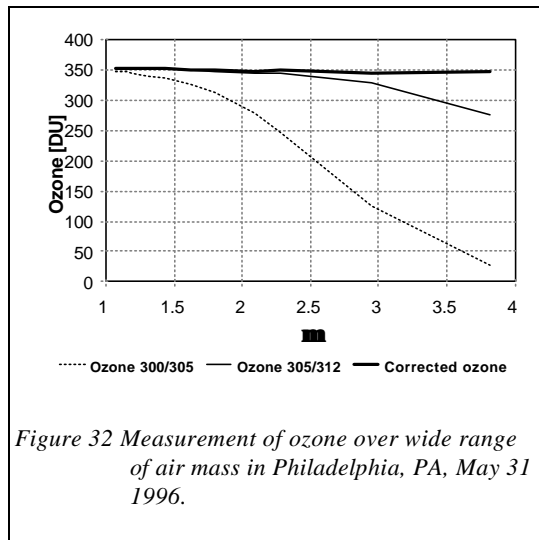
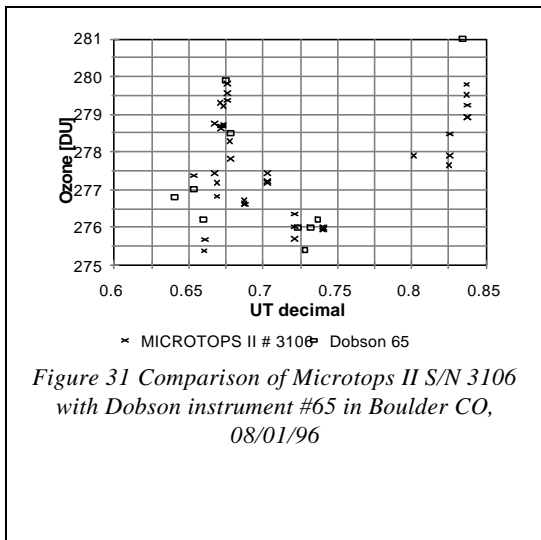

A radiation transfer model was used to calculate the spectral irradiance around 940nm for standard US atmosphere and various air masses. Subsequently the spectral irradiances from the model were multiplied by the 940nm filter's transmission curve producing the theoretical signal from 940nm detector. Based on (11) a set of k and b parameters was found that matches most closely the simulated results.

The V_{01} for the instrument is found from an extrapolation to air mass zero of the linearized (11):

$$\ln(V_1) + \tau_a m = \ln(V_{01}) - k(um)^b \quad (13)$$

The k and b are already known therefore $\ln(V_{01})$ is the intercept from linear regression of (13) versus m^b .

For the water vapor calculation the aerosol scattering coefficient τ_{a1} at 940nm is needed. In MICROTOPS II the aerosol scattering coefficient τ_{a2} at 1020nm is first measured based on (12). The V_{02} is obtained from extrapolation of a Langley plot on a sunny day. From the radiation transfer model a relationship between τ_{a1} and τ_{a2} is found for a standard atmosphere and because of a close proximity of the two bands it is assumed constant for other conditions. For the filters used in MICROTOPS II the relationship is:

$$\tau_{a1} = 1.16 \tau_{a2} \quad (14)$$

From (12), (13) and (14) the vertical water vapor column is calculated as:

$$u = \left(\frac{t_{a2} m (1 - 1.16) - \ln \left(\frac{V_1 V_{02}}{V_2 V_{01}} \right)}{k m^b} \right)^{1/b} \quad (15)$$

9.6 Conclusions

The MICROTOPS II is a low-cost hand-held instrument allowing quick and accurate ozone column and water vapor measurements. Tests indicate that the instrument gives reproducible results under various weather and climatic conditions.

Figure 31 shows the results of a comparison between Dobson spectrophotometer and MICROTOPS II instrument carried out in Boulder, Colorado, during a demonstration of the Dobson instrument (courtesy NOAA Climate Monitoring and Diagnostic Laboratory). The MICROTOPS II instrument was previously calibrated in Mauna Loa, Hawaii, under substantially different climatic conditions. Comparisons with other instruments are under way and early data indicate good agreement.

The typical agreement between multiple MICROTOPS II instruments is within 1-2%. The repeatability of consecutive ozone measurements is better than 0.5% (Table 3). Measurements through broken clouds or in very hazy conditions show variability of 1-2%.

Similarly to other spectrophotometers¹⁸ the MICROTOPS II exhibits some air mass dependency. This effect contributed to by out-of-band radiation leaks, scattering of diffuse UV radiation into the instrument's field of view and the effect of the finite bandwidth of the filter itself. Figure 32 shows a series of measurements performed during a sunny day in Philadelphia, PA over a wide range of m . The ozone calculations based on a single pair, for example 300/305nm or 305/312nm show the air mass dependence effect. With the air-mass dependence correction the measurements can be made to an air-mass of 3.8.

The quality of calibration depends strongly on weather conditions when the Langley method is used, limiting where and when the calibration can be performed. A calibration based on spectroradiometric measurements of individual filters is proposed^{5,6} but more experimental data is needed to test its applicability.

9.7 References:

1. G.P.Gaushchin et.al. Total ozone measuring instrument used at the USSR station network, in Atmospheric Ozone, edited by: C.S. Zeferos and A. Ghazi, Reidel, Dordrecht (1985)
2. A. Smajkiewicz *Filter durability, effect of temperature, humidity, radiation and time*, Barr Associates Inc., private communication
3. Forrest M. Mims III., How to Measure the Ozone Layer Science Probe 2, 4, 45-51, November 1992.

4. Forrest M. Mims III and E. R. Mims, Fluctuations in *Column Ozone During the Total Solar Eclipse of July 11, 1991*, Geophysical Research Letters, 20, 5, 367-370, 1993.
5. G.J.Labow et.al. *Estimating Ozone with TOPS Instruments - Practical Operation and Comparisons*, in press
6. Lawrence E.Flynn *Estimating Ozone with TOPS Instruments Theoretical Model and Error Analysis*, in press
7. *Basher and R. W. L. Thomas, Applied Optics, 18, 3361-62 (1979).*
8. D. Kohmyr, R.D. Grass and R. K. Leonard, *J. Geophys. Res.*, **94**, 9847-61 (1989).
9. D. Kohmyr, *Operations Handbook - Ozone Observations with a Dobson Spectrometer*, WMO, June, 1980.
10. J.Meeus, *Astronomical algorithms*, 1st ed. , Willmann-Bell, 1991
11. G. M. B. Dobson and C. W. B. Normand, *Ann. Int. Geophys. Year.*, **5**, 161-191 (1962)
12. S. Bannasch, G. Unger, and P. Wagoner, "Preliminary Calibration of TERC Total Ozone Spectrometers," TERC, private communication
13. L. T. Molina and M. J. Molina, *J. Geophys. Res.*, **91**, 14501-508 (1986).
14. R. Penndorf, *J. Opt. Soc. Amer.*, **47**, 176-82 (1957).
15. F.E.Fowle, *The spectroscopic determination of aqueous vapor*, Astrophys. J., 35, 149-162, 1912
16. J. Reagan, K.Thome, B.Herman, R.Gall, *Water vapor measurements in the 0.94 micron absorption band: calibration , measurements and data applications*, Proceedings, International Geoscience and Remote Sensing Symposium, Ann Harbor, 1987
17. J.J Michalsky, J.C.Liljegren, L.C.Harrison *A comparison of Sun photometer derivations of total column water vapor and ozone to standard measures of the same at the Southern Great Plains Atmospheric Radiation Measurement site*, JGR, Vol 100, No. D12, pp.25995-26003, 1995
18. M.Degorska, B.Rajewska-Wiech, *Airmass-Dependent Total Ozone Measurement Errors*, Publications of Institute of Geophysics, Polish Academy of Sciences, D-40, 263,(1993)

10 Table of figures

<i>Figure 1 Simplified Microtops II menu</i>	8
<i>Figure 2 Entering the date and time editing mode</i>	10
<i>Figure 3 Setting the clock trimmer</i>	11
<i>Figure 4 Modifying irradiance calibration constants</i>	12
<i>Figure 5 Modifying AOT calibration constants</i>	12
<i>Figure 6 Modifying water vapor calibration constants</i>	13
<i>Figure 7 Setting the scan length</i>	15
<i>Figure 8 Restoring factory calibration constants</i>	15
<i>Figure 9 Setting the number of top ranking samples</i>	16
<i>Figure 10 Setting the line frequency rejection mode.</i>	16
<i>Figure 11 Selecting a saved location</i>	17
<i>Figure 12 Setting current location altitude.</i>	17
<i>Figure 13 Setting current location geographic coordinates.</i>	18
<i>Figure 14 Figure Setting the station pressure.</i>	19
<i>Figure 15 Clearing the entire memory buffer.</i>	20
<i>Figure 16 Mean barometric pressure vs. altitude</i>	21
<i>Figure 17 Viewing the stored data on LCD</i>	22
<i>Figure 18 Deleting last data record.</i>	23
<i>Figure 19 Adjusting serial port speed (baud rate).</i>	24
<i>Figure 20 Serial communication cable for MICROTOPS II</i>	25
<i>Figure 21 MICROTOPS II remote menu</i>	25
<i>Figure 22 Listing of saved locations database.</i>	27
<i>Figure 23 Location input pattern.</i>	27
<i>Figure 24 Data transfer format. Long lines are wrapped around and a {CR} marker is placed where the carriage return character is sent.</i>	28
<i>Figure 25 Printout of MICROTOPS II calibration constants.</i>	30
<i>Figure 26 MICROTOPS II structure.</i>	42
<i>Figure 27 Spectral transmission of UV filters measured using a monochromator with 2.5nm slit width (notice bandwidth broadening) in order to detect the stray light.</i>	43
<i>Figure 28 . Signal measured by MICROTOPS II on Mauna Loa (May 16, 1996, 271DU, clear sky)</i>	44
<i>Figure 29 Series of consecutive MICROTOPS II measurements of ozone employing three different ways of sun targeting:</i>	46
<i>Figure 30 Illustration of the MICROTOPS II calibration procedure.</i>	47
<i>Figure 31 Comparison of Microtops II S/N 3106 with Dobson instrument #65 in Boulder CO, 08/01/96</i>	50
<i>Figure 32 Measurement of ozone over wide range of air mass in Philadelphia, PA, May 31 1996.</i>	50

11 Index

- A**
- A/D converter 5, 12, 17, 42, 43
 - air mass.....18, 40, 42, 47, 48, 49
 - altitude6, 17, 19, 20, 26, 28
 - AOT5, 6, 8, 12, 13, 14, 15, 18, 20, 21, 37, 38
 - averaging..... 16, 17, 43
- B**
- Battery
 - maintenance 36
 - Baud rate.....23
 - browse mode21, 22
- C**
- calibration .. 5, 12, 13, 14, 15, 16, 17, 20, 22, 24, 28, 29, 33, 36, 37, 39, 43, 45, 47, 49, 50
 - calibration constants6, 12, 13, 14, 15, 28
 - circumsolar radiation.....5, 12
 - cleaning 36
 - Clearing data buffer.....26, 30
 - Clearing the memory.....21, 22
 - clock 10, 11, 27, 35, 40, 43, 45
 - clock trimmer 10
 - collimator..... 5
 - collimators5, 41
 - Computer communication 24
 - Coordinates19, 22
 - current location17, 18, 19, 20, 24, 25
- D**
- Data description..... 33
 - data exchange format..... 33
 - Data processing 16
 - data storage 20
 - Database32, 33
 - digital filter16, 18
 - Downloading of data..... 30
- F**
- factory calibrations12, 15
 - features..... 5
- G**
- geographical coordinates 18
 - GPS..... 6, 23, 25, 34, 35
- I**
- Importing text 32
 - irradiance.....12, 13, 22, 37, 38, 48
- L**
- latitude26
 - Line frequency.....17, 18
 - Location setup 18
 - Locations 31
 - longitude..... 19
- M**
- maintenance 36
 - menu 7
 - Microtops Organizer.....24, 26, 27, 29
- N**
- Non-volatile memory..... 6
 - number editing 13, 14, 15, 17, 20
- O**
- optical block 5, 22, 28, 40, 41
 - ozone absorption 13, 44, 46
- P**
- precipitable water 5, 39, 40
 - Pressure..... 15, 18, 20, 22, 25
 - pressure sensor15, 20, 25, 28, 35, 41

Q

Query 32

R

Rayleigh scattering.....20, 41, 44, 46

Remote control..... 25

Restoring factory calibrations..... 15

S

Scan length..... 16

serial cable 24

serial port . 12, 16, 18, 21, 23, 24, 26, 27, 29,
34

solar zenith angle.....10, 18, 43, 45

sun target 5

T

time and date 10

U

user calibrations12, 28

UT 10, 27, 45

Wwater vapor....5, 6, 10, 12, 13, 14, 15, 18, 20,
37, 39, 47, 48, 50